

# 1373 1377

## 取扱説明書 使用说明书

## INSTRUCTION MANUAL

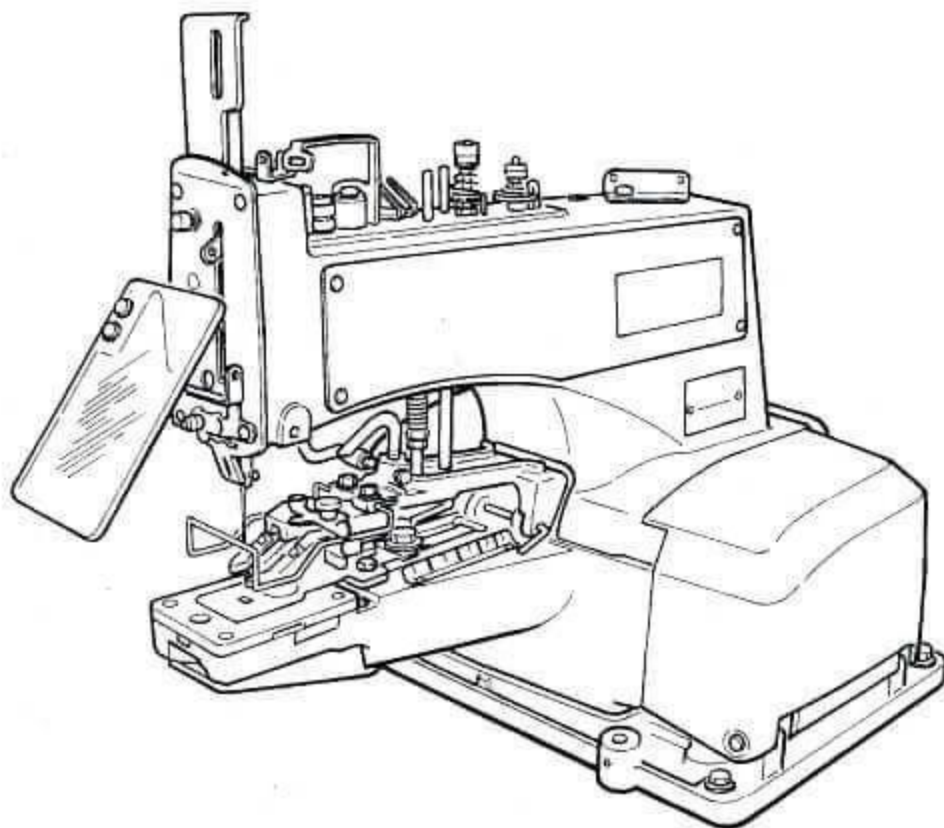

**注意：** このたびは、当社の製品をお買い上げいただきまして、ありがとうございました。安全に使用していただくために使用前に、必ずこの取扱説明書をお読みください。また、いつでもすぐに読めるように、この取扱説明書を保管してください。

**NOTE :** Read safety instructions carefully and understand them before using. Retain this Instruction Manual for future reference.

**注意：** 为了安全地使用，请您在使用之前一定阅读本使用说明书。另外，请您注意保管本使用说明书，以便随时查阅。

# 目 录

## CONTENTS

- 使用说明书.....

INSTRUCTION MANUAL

- 零件目录.....

PARTS LIST

## 重要安全事项

- 1.使用此缝纫机时，必须遵守包括如下项目的基本安全措施。
- 2.使用此缝纫机之前，请阅读本说明书在内的所有指示文件。同时应将此使用说明书妥善保管，以便能够随时查阅。
- 3.此缝纫机与贵国的安全规定一起使用。
- 4.使用此缝纫机和缝纫机动作中，所有的安全装置应安装到规定的位置。没有安装规定的安全装置的缝纫机禁止使用
- 5.此缝纫机应由接受过培训的操作人员来操作。
- 6.使用缝纫机时，建议戴安全防护眼镜。
- 7.发生下列情况时，应立即关掉电源开关，或拔下电源线插头。
  - 7-1 机针、弯针、分离器等穿线和更换旋梭时
  - 7-2 更换机针、压脚、针板、弯针、分离器、送布牙、护指器、支架、布导向器等时。
  - 7-3 修理时
  - 7-4 工作场所无人或离开工作场所时
  - 7-5 使用离合马达时，请等待马达完全停止之后再行
- 8.缝纫机以及附属装置使用的机油、润滑脂等液体流入眼睛或沾到皮肤上时，或被误饮时，应立即清洗有关部分并去医院治疗。

- 1.Observe the basic safety measures ,including,but not limited to the following ones ,whenever you use the machine.
- 2.Read all the instructions ,including ,but not limited to this instruction Manual before you use the machine In addition ,keep this Instructions Manual so that you may read it at anytime when necessary.
- 3.Use the machine after it has been ascertained that it conforms with safty rules/standards valid in your country. .
- 4.All safety devices must be in position when the machine is ready for work or in operation. The operation without the specified by safety devices is not allowed..
- 5.This machine shall be operated by appropriately–trained operators.
6. For your personal protection we recommend that you wear safety glasses
7. For the following ,turn off the power switch or disconnect the power plug of the machine from the receptacle.
  - 7-1 For threading needle ,looper ,spreader etc .and replacing bobbin.
  - 7-2 For replacing parts of needle ,presser foot ,throat plate ,looper ,spreader ,feed dog ,needle guard folder ,cloth guide ect.
  - 7-3 For repair work
  - 7-4 When leaving the working place or when the working place is unattended.
  - 7-5 When using clutch motors without applying brake , it has to be waited until the motor stopped totally .
8. If you should allow oil ,grease ,ect .used with the machine and devices to come in contact with your eyes or skin or swallow any of such liquid by mistake ,immediately wash the contacted areas and consult a medical doctor.

- 9.禁止用手触摸打开了缝纫机开关通电的零件或装置。
10. 有关缝纫机的修理、改造、调整应由受过专门训练的技术人员或专家来进行。
11. 一般的维修保养应由受过训练的人员来进行
12. 有关缝纫机的电气方面的修理、维修应由有资格的电气技术人员或专家的监督和指导下进行。
13. 修理、保养有关空气、汽缸等压缩空气的零件时，应切断空气压缩机供气源后再进行。如有残留压缩空气时应放掉压缩空气。但，受过相当训练的技术人员或专家进行有关调整或确认动作时除外。
14. 缝纫机的使用期间应定期进行清扫。
- 9.Tampering with the live parts and devices ,regardless of whether the machine is powered ,is prohibited.

10. Repair ,remodeling and adjustment works must only be done by appropriately trained technicians or specially skilled personnel .Only spare parts designated by JOYEE can be used for repairs.
11. General maintenance and inspection works have to be done by appropriately trained personnel.
12. Repair and maintenance works of electrical compinents shall be conducted by qualified elecceic tech- nicians or under the audit and guidance of specially skilled personnel.
13. Before making repair and maintenance works on te\he machine equipped with pneumatic parts such as an air cylinder,the air compressor has to be detached from the machine and the compressed air supply has to be cut off.Existingresidual air pressure after disconnecting the air compressor from the machine has to be expelled.Exceptions to thisare only adjuustments and performance checks done by appropriately trained technicians or specially skilled persinnel.
- 14.Periodecally clean the machine throughout the period of use.

- 15.为了正常安全运转,应安装地线,同时应在不受高频焊接机等强噪音源影响的环境下使用.
16. 电源插头应用具有电气专门知识的人来安装.电源插头必须连接到接地插座上
- 15.Grounding the machine is always ncessary for the normal operation of the normal operation of the machine .The machine has to be operated in an environment that is free from strong noise sources such as high-frequency welder.
16. An appropriate power plug has to be attached to the machine by electric technicians .Power plug has to be connected to a grounded receptacle.

17. 缝纫机指定用途以外不能使用.
18. 对缝纫机的改造、变更应符合安全规格,并采取有效的安全措施.另外,对于有关改造和变更,JOYEE公司概不负责.
17. The machine is only allowed to be used for the purpose intended .Other used are not allowed.
18. Remodel or modify the machine in accorance with the safety rules/standards while taking all the effective safety measures. JOYEE assumes no responsibility for damage caused by remodeling or modification of the machine .



有发生中度轻伤、重伤、死亡的危險。触摸了活动部分的话有发生负伤的危險。  
 应安装安全防护器；然后再进行缝纫  
 应安全护罩；然后再进行缝纫  
 应安装保护装置；然后再进行缝纫  
 应关掉电源之后，再进行穿线、更换梭芯、机针、清扫、调整、加油

These is the possibility that slight to serious injury or death may be caused ,These is the possinility that injury may be caused by touching moving part .

To perform sewing work with safety guard ; To perform sewing work with safety cover

To perform sewing work with safety protection device.

Turn off the power and perform "threading" ,replacement of bobbin or needle ,cleaning ,adjustment ,and lubrication.



危险

1. 接通电源开关时和缝纫机运转中，请不要把手指放到机针下附近。
  2. 放倒缝纫机时，请关闭电源开关。
  3. 缝纫机运转中，请不要把手指、头发、衣服靠近飞轮、挑线杆附近，也不要物品放到上面。
  4. 请不要在卸下针杆护罩、手指防护罩、眼睛防护罩等安全装置的状态运转缝纫机。
  5. 放倒缝纫机时，请注意不要夹到手指。
1. To avoid personal injury, never put your fingers under the needle when you turn ON the power switch or operate the sewing machine.
  2. To avoid personal injury, turn OFF the power switch when you tilt the machine head.
  3. To prevent possible personal injury caused by being caught in the machine, keep your fingers, head and clothes away from the handwheel and the thread take-up while the sewing machine is in operation. In addition, place nothing around it.
  4. Never operate the machine with the safety devices such as needle bar cover, finger guard, eye guard cover, etc. removed.
  5. To avoid personal injury, be careful not to allow your fingers in the machine when tilting the machine head.



注意

1. 为了安全，在卸下电源地线的状态下，请不要运转缝纫机。
  2. 拔插电源插头时，请一定先关闭电源开关。
  3. 打雷时，为了安全请不要进行操作，同时请把电源插头拔下。
  4. 从寒冷的地方移动到暖和的地方等时，因为会结露，所以请待水分完全干后再接通电源。
  5. 为了防止火灾，请定期地从插座拔下电源插头，清扫插头的根部和插簧之间。
1. For the safety, never operate the sewing machine with the ground wire for the power supply removed.
  2. Be sure to turn OFF the power switch in prior when connecting / disconnecting the power plug.
  3. When thunders occurs, stop the work for the safety and disconnect the power plug.
  4. When the sewing machine is suddenly moved from a cold place to a warm place, there is a case where dew condensation may occur. Turn ON the power after there is no worry of the drop of water.
  5. To prevent fires, periodically draw out the power plug from the plug socket and clean the root of the pins and the space between pins.

- 请使用适合缝纫机规格的机油。
  - 第一次使用缝纫机之前，请把缝纫机打扫干净。
  - 请把运送中积的灰尘打扫干净。
  - 请确认是否设定的电压是否正确。
  - 请确认电源插头是否正确地插好。
  - 电源规格不同的情况时，请绝对不要使用缝纫机。
  - 缝纫机的转动方向是，站在飞轮侧看为顺时针方向。请注意不要让缝纫机反向转动。
  - 缝纫机出货时虽然完全地进行了调整，但是初次使用时，请卸下遮挡，用手稍稍转动之后再打开电源开关。
  - 设置缝纫机时，请一定把机头支撑杆插进机台之后再行设置。
  - 运转缝纫机时，正确地设置到机台之后再打开电源开关。
  - 待缝纫机确实停止之后再操作飞轮。
- Use the oil adaptable to the machine specifications.
  - Clean the sewing machine thoroughly before using it for the first time.
  - Remove all dust collected on the sewing machine during the transportation.
  - Confirm that the voltage and phase are correct.
  - Confirm that the power plug is properly connected.
  - Never use the sewing machine in the state where the voltage type is different from the designated one.
  - The direction of rotation of the sewing machine is clockwise as observed from the handwheel side. Be careful not to rotate it in reverse direction.
  - Before applying power, release the stop-motion mechanism and turn by hand the needle driving pulley in order to ensure that the machine is in order.
  - To install the machine, the frame support bar has to be firstly inserted into the table.
  - When operating the sewing machine, turn ON the power switch after properly setting the head on the table.
  - Operate the handwheel after the sewing machine has totally stopped.

## 一、规格 SPECIFICATIONS

缝纫速度 Sewing speed	正常1300rpm (最大1500rpm) Normal 1300rpm (Max 1500rpm)
针数 Number of stitches	8,16和32针 8,16 and 32 stitches
送布量 Feed amount	横向送布 2.5~6.5mm Lateral feed 2.5 to 6.5mm 纵向送布 0, 2.5~4.5mm Longitudinal feed 0, 2.5 to 4.5mm
纽扣尺寸 Button size	10~28mm 10 to 28mm
使用机针 Needle used	TQx1 #16(#14~#20) Tqx7 #16(#14~#20)
机油 Lubricating oil	缝纫机专用油 Oil for sewing machine

## 二、缝纫机的准备 PREPARATION OF THE SEWING MACHINE

把防震胶垫①放到机台上，然后把机头放到上面，用固定螺丝②、垫片③、螺母④固定好。然后把S型挂钩⑥和铁链⑦安装到起动环⑤上  
Put rubber cushion① on the table place the machine head on the rubber cushion and fix it to the table using screw ②, plain washers③ and nuts④. Attach "S" chain hook⑥ and chain⑦ to stop motion trip lever ⑤.

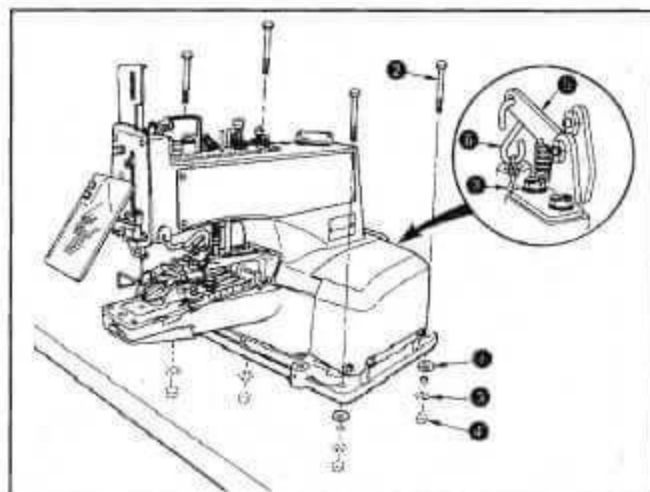

## 三、加油 LUBRICATION

- 1) 打开侧面护罩，向红色标记的部分①~⑫加入机油（每星期1~2次，每次大约加油1cc).
  - 2) 拧送安装螺丝⑬，放倒缝纫机，把润滑脂加到螺丝齿轮⑮和蜗轮齿轮⑯上。
  - 3) 每周检查1次机座安装台内的加油毛毡上面是不是吸满油，油不够时请加油，同时往曲轴⑭上加油。
- 1) Open the side cover, and apply oil to the portions shown by the red red marks① to ⑫ (Apply approximately 1 cc of oil to the respective lubricating places one to two times a week)
  - 2) Loosen connecting screw ⑬ tilt the machine head backward and apply grease to crossed helical gear ⑮ and worm gear ⑯
  - 3) Check, approximately once a week, that oil amount is sufficient to reach the top of the oil felt placed inside the bed mounting base. If the amount of oil is insufficient, add an adequate amount of oil. At this time, also apply oil to crank rod ⑭

**注意 WARNING:** 为了防止突然起动造成人身事故，请关掉电源，确认马达确实停止转动后再进行。  
To protect against possible personal injury due to abrupt start of the machine, be sure to start the following work after turning the power off and ascertaining that the motor is at rest

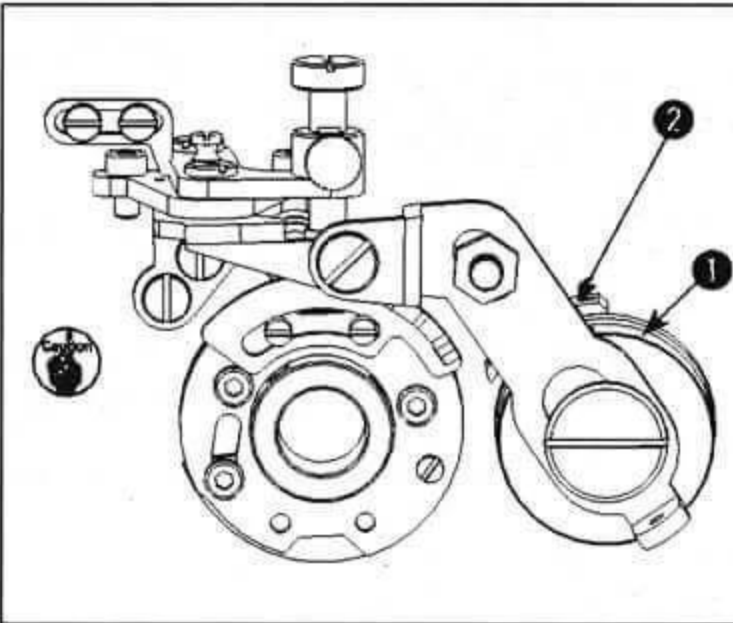
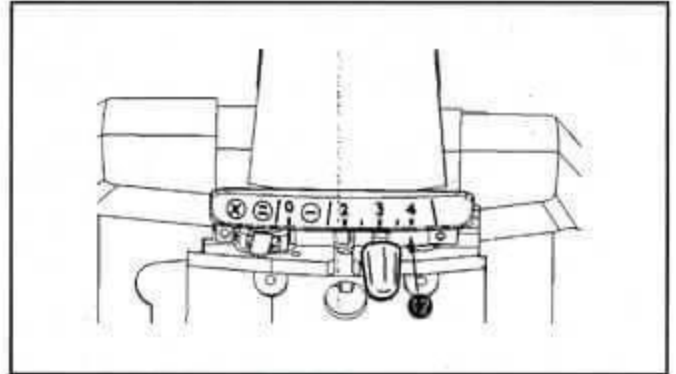
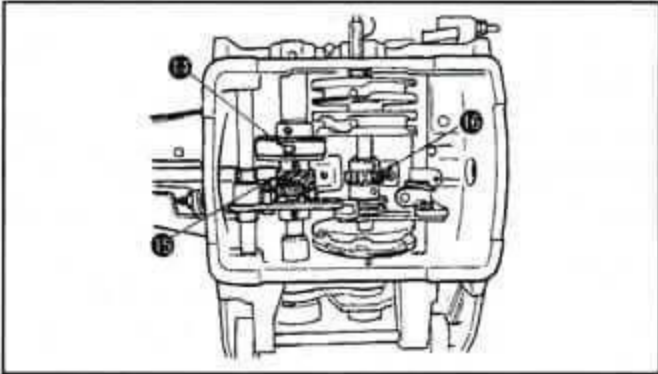
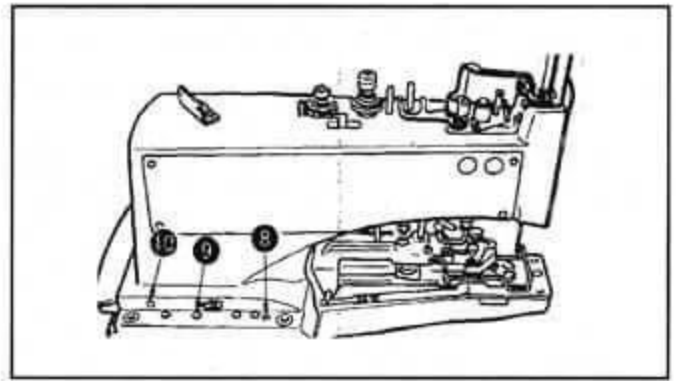
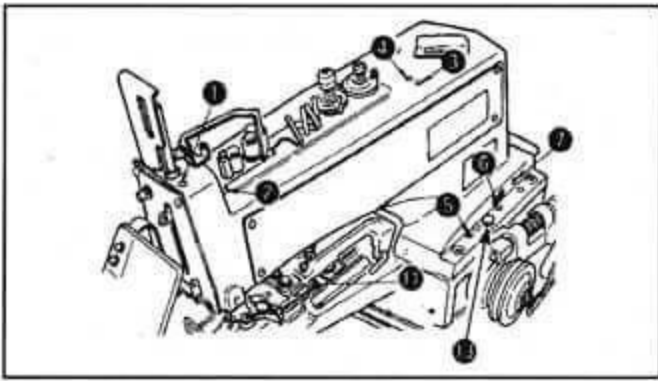

#### 加油时的注意事项

1. 预备停止摩擦轮①和摩擦板②具有防止减速性能降低的功能，因此请注意不要粘附油类。如果粘附到油时，请擦拭干净

2. 为了防止缝纫机皮带劣化，请注意不要让缝纫机皮带粘附油类物质

#### Caution at the time of lubricating

1. Take care not to allow speed slowing friction wheel and friction plate to be clogged with oil to prevent them from the deterioration of retardation performance. In addition, when the components are clogged with oil wipe the oil from them

2. Take care not to allow the machine belt to be clogged with oil to prevent it from the deterioration.

## 四、针杆防护罩的安装方法 Attaching the needle

- 1) 拧松固定螺丝②，卸下线调整导线器③。
- 2) 把针杆护罩①安装到线调节导线器③的下面，启动时让紧线杆④移动导线调节导线器③的中心。
- 3) 用固定螺丝②固定针杆罩

- 1) Loose screw ② and remove thread guide ③
- 2) Place needle bar guard ① under thread guide ③ and attach guide ③ so that lever ④ comes to the center of it at the start of the machine .
- 3) Fix the cover with screw ②

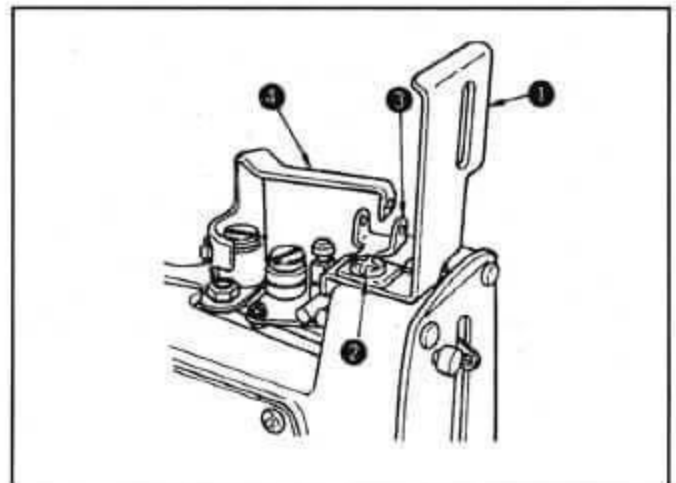

## 五、纽扣盘的安装 Attaching the needle bar cover

把纽扣盘①插进机座前部的右侧的孔上，并把固定螺丝②拧紧固定，如果，右侧抓纽扣不方便的话，请改装到左侧。

Insert the posts of button tray ① in hole on the right of the machine sub-base and tighten each setscrew ②.

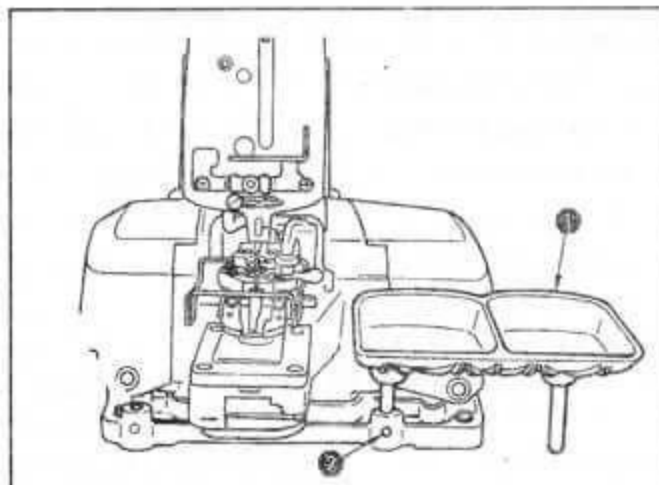

## 六、上线的穿线方法 Threading the machine

按照图的①~④的顺序穿线，从针孔的前面向后方按压夹线器松线杆螺母，并把线拉出约60~70mm标准机针是TQx1 #16缝纫机针④

Thread the machine head in the order of ① to ④ as shown in the illustration given above, then, pass the thread through the needle eye from the front for approximately 60 to 70mm as you depress nipper releasing knurled thumb nut

Standard needle is Tqx1 #16④

**注意WARNING** 为了防止突然启动造成人身事故，请关掉电源，确认马达确实停止转动后再进行。

To protect against possible personal injury due to abrupt start of the machine, be sure to stop the start the following work after turning the power off and ascertaining that the motor is at rest

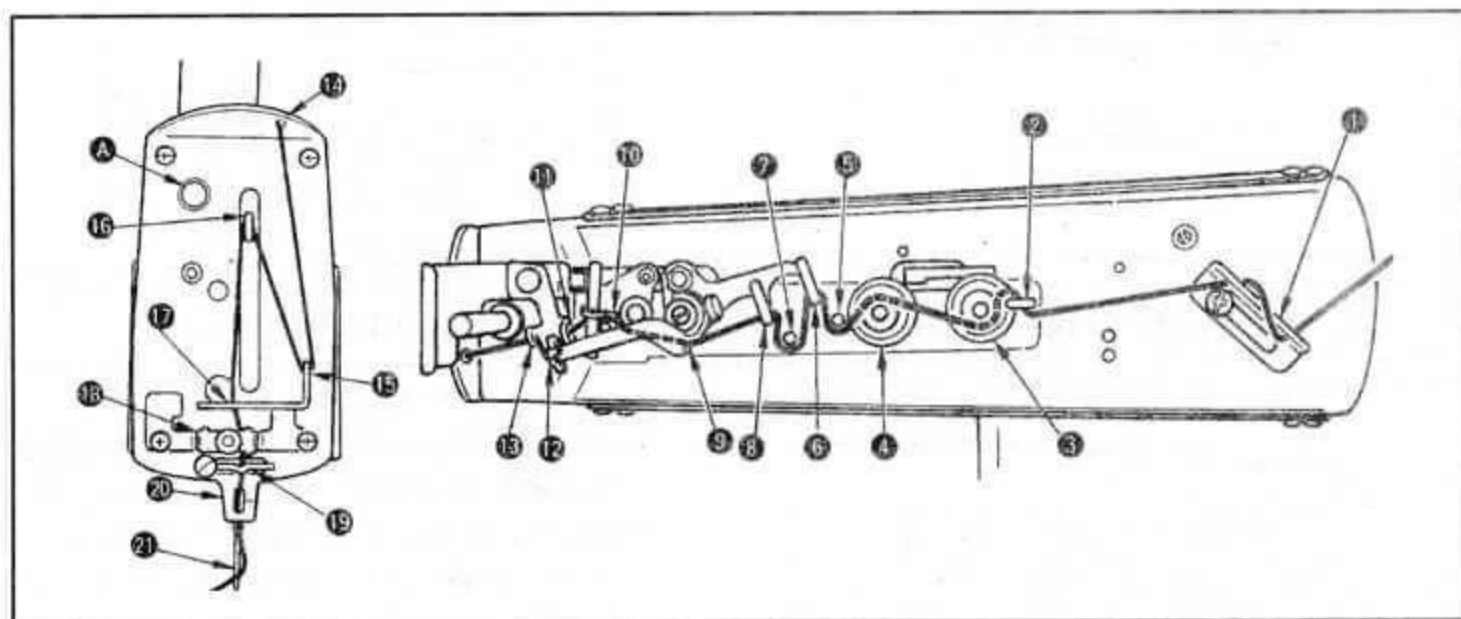

## 七、线张力 Thread tension adjustment

第一线张力螺母①是调整钉扣强度用的，仅能调整微小的张力。

第二线张力调整螺母②是调整背面的紧线程度的，其张力比第一线张力螺母①强，根据使用的机线、布料、纽扣厚度等情况进行调整。

向右转动各线张力螺母之后，线张力变强，向左转动则张力变弱。

Tension post No1 ❶ is used to adjust the thread tension to sew on the button and a relatively low tension will be enough, Tension post No2 ❷ is used to adjust the thread tension applied to the root of the button sewing stitches, This tension must be determined according to the type of thread, fabric and thickness of the button and must be higher than that of tension post No1 ❶ Turn the tension nuts clockwise to increase or counterclockwise to reduce the thread tension

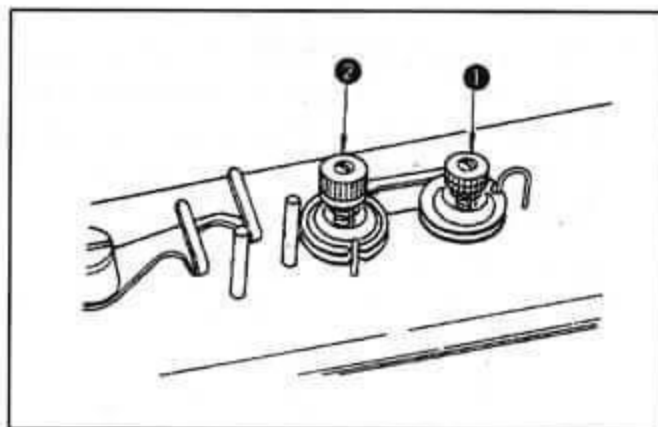

## 八、线调整杆的调整 Adjustment of the thread pull-off lever

调整线调整杆时，请把螺丝刀插进左侧面板上的孔中，拧松固定螺丝，然后左右移动调整杆的活动滑块进行调整。缝制结束。如果线头从A部箭头的孔中露出时，请把线调整杆活动滑块向左移动，如果线头从B部箭头的孔中露出时，请把滑块向右移动，不让线头露出来。

To adjust the thread pull-off lever insert a screwdriver through an opening in the machine arm side cover (left), loosen screw and adjust the position of nipper block (rear) to the left or the right. If the end of thread is drawn from arrow hole A in the button after sewing, change the position of nipper bar block (rear) to the left. Move the lever to the right when the thread end comes out from arrow hole B.

**注意WARNING** 为了防止突然启动造成人身事故，请关掉电源，确认马达确实停止转动后再进行。

To protect against possible personal injury due to abrupt start of the machine, be sure to stop the following work after turning the power off and ascertaining that the motor is at rest

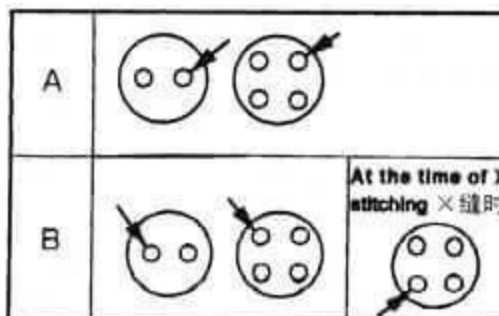
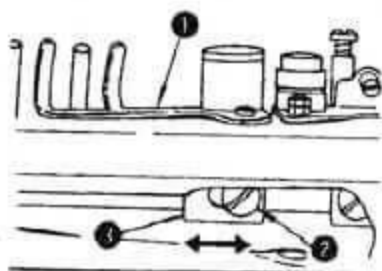

## 九、紧线拨杆的调整 Adjustment of the thread pull-off lever

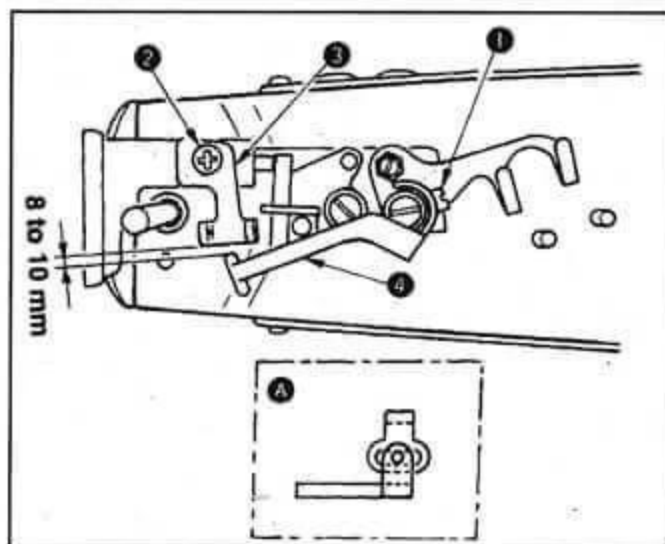

- 1) 在分离时，拧松固定螺丝 ❶
- 2) 把线张力导向器 ❸ 的端面和紧线杆 ❹ 的端面的距离调整为8~10mm，然后拧紧固定螺丝 ❶

When the machine is in the stop-motion state, loosen screw ❶ Tighten setscrew ❶ so that there is a clearance of 8 to 10 mm as a standard between the end of thread tension guide ❸ and ❹ end of lever.

注意：调整后，请确认启动时线道如图A所示在长孔的范围内。如果不正确时，请拧松线张力导线器固定螺丝 ❷，进行调整。

After the adjustment, make sure that the thread path is within the slot as illustrated in fig A. When the machine starts, if the thread paths do not coincide with each other, loosen screw ② in the tension thread guide and adjust it properly.

**注意WARNING** 为了防止突然启动造成人身事故，请关掉电源，确认马达确实停止转动后再进行。

To protect against possible personal injury due to abrupt start of the machine, be sure to the start the following work after turning the power off and ascertaining that the motor is at rest

## 十、紧线拨杆的调整 Adjustment of the thread pull-off lever

1) 运转时，把针器①的方块②和拨针器①的间隙调整为0.4~0.6mm，不让拨针器①压住机线

2) 调整方法是，拧松固定螺丝③，左右移动拨针器活动滑块④

1) Provide a 0.4 to 0.6mm clearance between nipper block ② and nipper ① to prevent the nipper ① from holding the thread while the machine is in operation

2) Loosen screw ③ and move nipper bar block ④ to the right or the left.

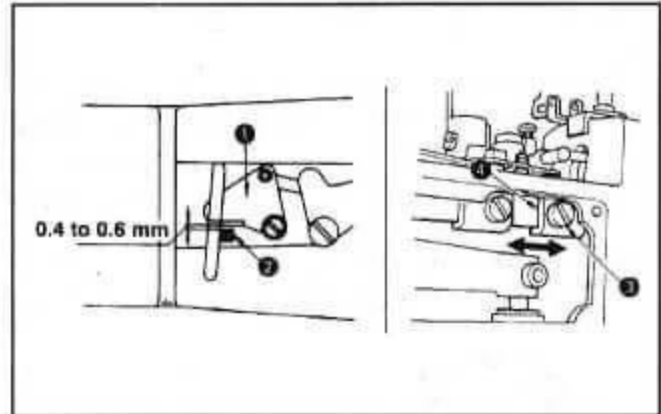

**注意WARNING** 为了防止突然启动造成人身事故，请关掉电源，确认马达确实停止转动后再进行。

To protect against possible personal injury due to abrupt start of the machine, be sure to the start the following work after turning the power off and ascertaining that the motor is at rest

## 十一、面线张力器的调整 Adjusting the thread tension guide on the face plate

缝制开始不能形成缝迹，而是从中途形成的缝迹，调整了线调节杆也不能纠正时，请转动旋钮螺母①，减弱线张力

①，减弱线张力

If the formation of seams at the start of sewing is failed and the seams are formed on the way even, when the thread pull-off lever is adjusted, turn thumb nut ① to decrease the thread tension.

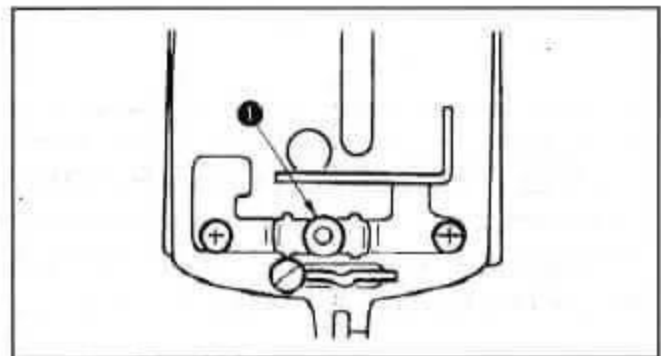

## 十二、机针和弯针的关系 Need-to-looper relation

机针和弯针按如下方法进行调整

1) 在把踏板踩到底的状态下，用手向转动方向转动驱动皮带轮下降到最低点，然后拧松固定螺丝（决定针杆高度）

2) TQX1针时，请把针杆②的上方2条刻线中的上刻线A对准针杆下滑块③的下端；TQX7针时，请把下方的2条刻线A对准针杆下滑块③的下端，然后拧紧固定螺丝①。此时，请把针的槽C调整到上面。（决定弯针的位置）

3) 拧松螺钉④，转动皮带驱动轮，把针杆②的2条一组的刻线中的下刻线B对准针杆下滑块③的下端。

4) 在此状态，把弯针的针尖⑤对准机针的中心，然后拧紧固定螺丝④

5) 拧松固定螺丝⑥，把弯针间隙调整为0.01~0.1mm，然后拧紧螺丝⑥。

Adjust the needle-to-looper relation as follows:

- 1) Depress the pedal fully forward, turn the needle driving pulley in the normal sewing direction by hand to bring down the needle bar to the lowest position of its stroke and loosen screw ❶ (adjusting the needle bar height)
- 2) Adjust the height of the needle bar using the top two lines engraved on the needle bar ❷ for the TQX1 needle and using the bottom two lines for the TQX7 needle. Align the upper line A with the bottom end face of needle bar bushing (lower) ❸ and tighten screw ❶. At this time, tighten the screw so that groove C of the needle faces the front.
- 3) Loosen screw ❷ and turn by hand the needle driving pulley until lower line B of two lines aligns with the bottom end face of needle bar bushing (lower) ❸
- 4) By keeping the machine in this state, align looper blade ❹ with the center of the needle and tighten screws ❸
- 5) Loosen screws ❸ and provide a 0.01 to 0.1mm clearance between the looper and the needle tighten screws ❹

**注意WARNING** 为了防止突然启动造成人身事故，请关掉电源，确认马达确实停止转动后再进行。

To protect against possible personal injury due to abrupt start of the machine, be sure to stop the following work after turning the power off and ascertaining that the motor is at rest

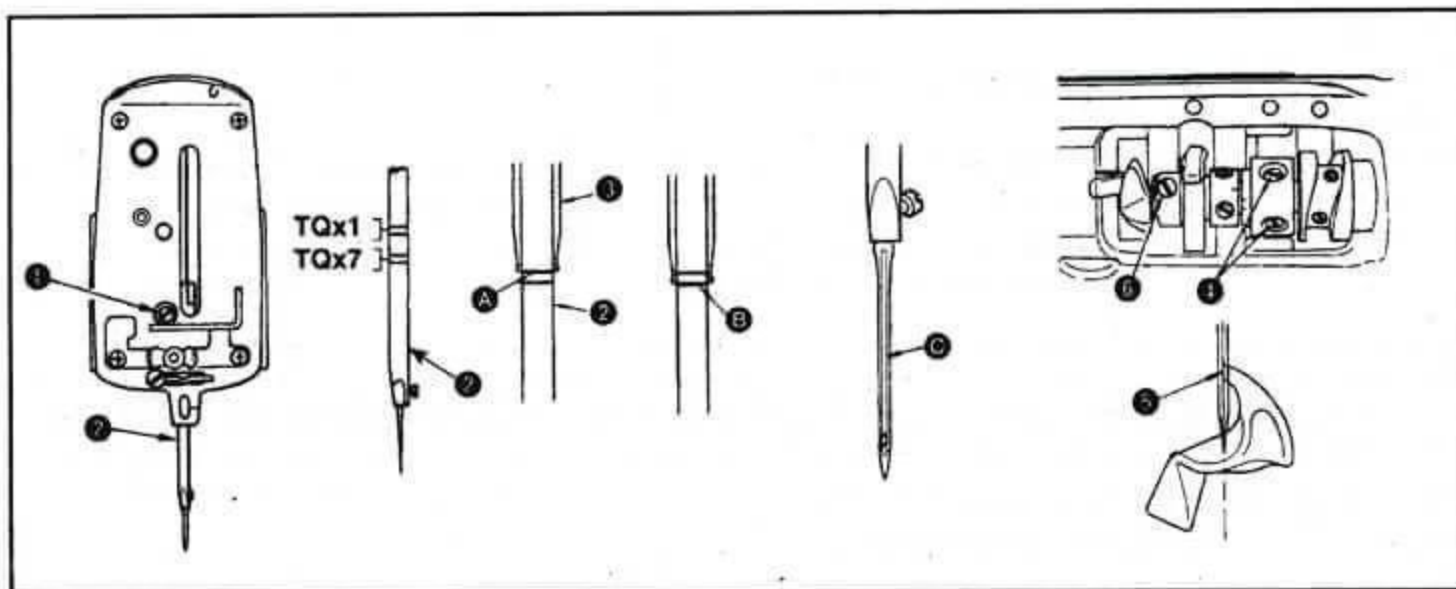

### 十三、针导向器的位置 Position of needle guide

在针杆最下点，拧松螺丝 ❷，左右移动针导向器 ❶，把机针和导向器 ❶ 的间隙调整为 0.05~0.1 mm.

Loose screw ❷ and provide a 0.05 to 0.1mm clearance between the needle guide ❶ and the needle by moving the needle guide ❶ to the left or the right when the needle is in the lowest position.

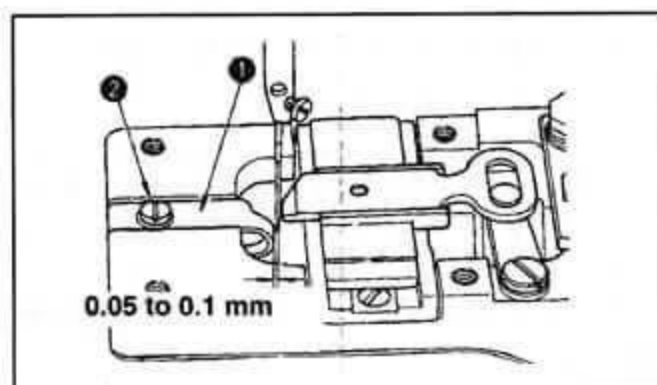

**注意WARNING** 为了防止突然启动造成人身事故，请关掉电源，确认马达确实停止转动后再进行。

To protect against possible personal injury due to abrupt start of the machine, be sure to stop the following work after turning the power off and ascertaining that the motor is at rest

## 十四、抓扣装置的高度 Height of the button clamp

1)在缝制后停止的位置，纽扣抓爪 ① 的底面里侧和压脚下板 ② 的间隙A是8mm

2)调整时，拧松抓脚提升钩固定螺丝 ③，上下移动抓脚装置提升钩 ④。

1)The standard clearance A between the rear side of the bottom face of button clamp jaw lever ① and the top surface of feed plate ② is 8mm at the position where the machine has stopped after sewing.

2)To adjust the height of the button clamp unit, loosen screw ③ in the button clamp lifting hook and move button clamp lifting hook ④ up or down.

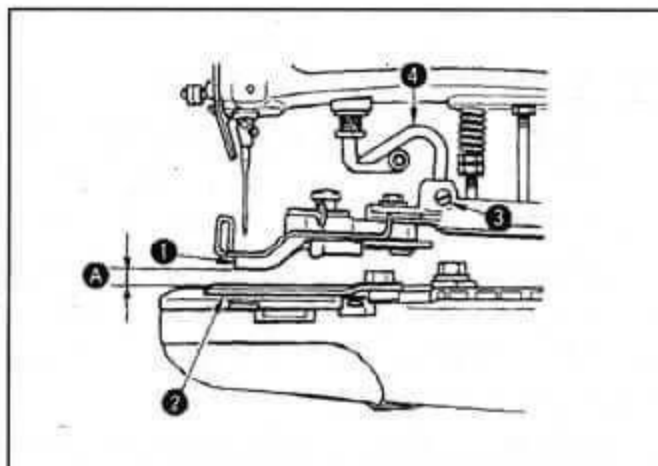

**注意WARNING** 为了防止突然启动造成人身事故，请关掉电源，确认马达确实停止转动后再进行。

To protect against possible personal injury due to abrupt start of the machine, be sure to stop the following work after turning the power off and ascertaining that the motor is at rest.

## 十五、压脚压力的调整 Work pressing force

螺母 ① 的上端和压脚压力调节杆 ② 下端的间隔为 28.5~29.5mm 时的布压脚压力是标准压力。请转动螺母 ① 进行调节。

The standard work pressing force is by providing a 28.5 to 29.5 mm between the top end of nut ① and the bottom end of pressure adjusting bar ②. Turn nut ① to adjust it.

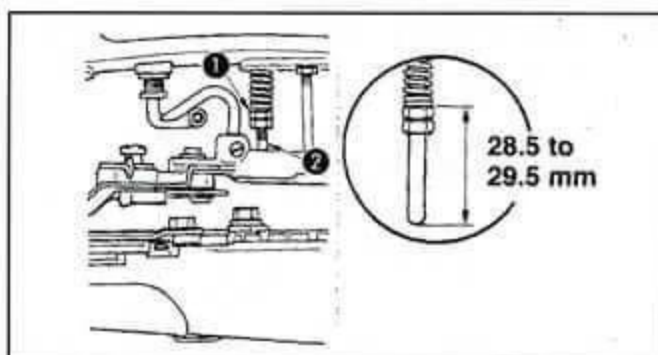

**注意WARNING** 为了防止突然启动造成人身事故，请关掉电源，确认马达确实停止转动后再进行。

To protect against possible personal injury due to abrupt start of the machine, be sure to stop the following work after turning the power off and ascertaining that the motor is at rest.

## 十六、抓脚打开拨杆的调整 Adjustment of the button clamp stop lever

在遮挡状态，拧松了固定螺丝 ① 的话，可以用爪脚张开杆 ② 开闭纽扣爪脚 ③。把纽扣安放到正确的位置，然后在纽扣容易放入取出的位置用固定螺丝 ① 固定爪脚张开杆 ②。

When clamp screw ① is loosened in the state of stop-motion, button clamp jaw levers ③ opens/closes with button clamp stop lever ②. Set a button to the correct position and fix button clamp stop lever ② at the position where taking in and out of the button is easily performed with clamp screw ①.

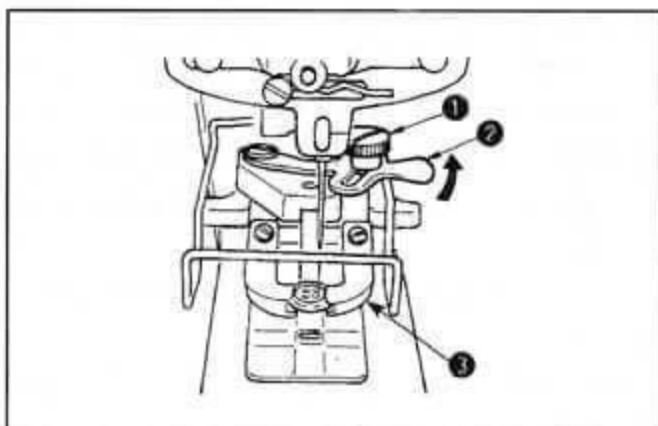

**注意WARNING** 为了防止突然启动造成人身事故，请关掉电源，确认马达确实停止转动后再进行。  
To protect against possible personal injury due to abrupt start of the machine ,be sure to the start the following work after turning the power off and ascertaining that the motor is at rest

## 十七、松线同步时间的调整 Timing of thread tension release

一边向箭头 **A** 方向拉线，一边转动驱动皮带轮时，第二线张力盘浮起，有个线迅速脱线的点。此时，从针杆上金属滑块上面到针杆上端的高度为44~47 mm ( TQX7针时为54~57mm ) 是标准。特别是经常发生下列现象时，请进行以下调节。  
拧松螺母 **1**，把螺丝刀插入第二线张力杆，向箭头 **B** 方向转动之后，线盘浮起，针杆高度变低，向相反的方向转动之后则针杆高度变高。

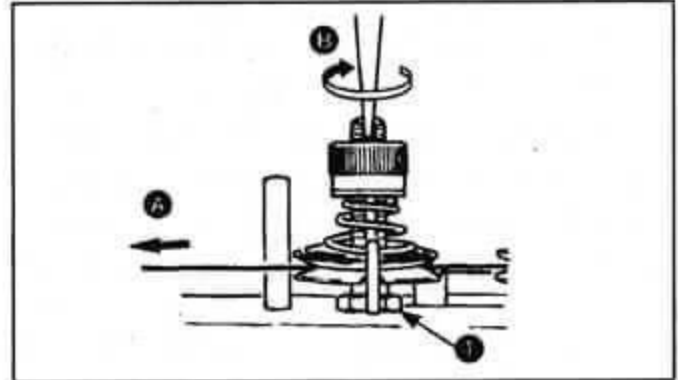

Turn the needle driving pulley as you draw the thread in the direction of arrow mark **A** and you will find a point at which the tension discs on the tension post No.2 release the thread . At this moment ,the standard distance from the top end of the needle bar bushing (upper) to the end of the needle bar is 44 to 47mm(in case of the needle of TQX7,54 to 57mm). Perform the following adjustments especially when the undermentioned troubles occur frequently,Loosen nut **1** , insert the blade of a screwdriver to the top slot of the tension post No.2 and turn it in the direction of arrow mark **B** to the lower the height of the thread floating bar and in the opposite direction to raise the height.

现象	针杆高度
1.布料里侧的紧线不好时	稍稍高一点
2.断开时，机线中途断线时	稍稍低一点
3.经常断线	稍稍低一点

Phenomenon	Height of thread floating bar
1.When the stitch made on the wrong side of the workpiece is too loose	Make the needle bar slightly higher
2.When the thread is broken at the time of stop-motion	Make the needle bar slightly lower
3.When the thread is broken frequently	Make the needle bar slightly lower

**注意WARNING** 为了防止突然启动造成人身事故，请关掉电源，确认马达确实停止转动后再进行。  
To protect against possible personal injury due to abrupt start of the machine ,be sure to the start the following work after turning the power off and ascertaining that the motor is at rest

## 十八、2眼和4眼扣的调整 Setting for 2-or 4-hole buttons

请确认了缝纫机在遮挡位置之后再进行调整

首先量一下纽扣孔间隔有几mm，4眼纽扣的竖送量和横送量值应设为相同。

竖送量

向下压竖送调整杆 **1**，2眼纽扣时设到0的位置，4眼纽扣时根据测定值进行设定。

横送量

拧松螺母 **2**，把指针 **3** 的 **A** 部对准对应测定值的刻度，然后拧紧固定螺母 **2**。

花样的选择：

4扣眼时请根据缝制需要按下列方法进行调整。放下压脚，将 **4** 压下并且向需要的方向转动，然后落下

Perform the adjustment after confirming that the sewing machine is located at the position of the stop-motion

Measure the distance between two holes in a button and set equally crosswise and lengthwise feed regulators for 4-hole buttons.

Lengthwise feed

Push down lengthwise feed adjusting lever ❶ and set it to "0" for 0-hole buttons or a corresponding amount for 4-hole buttons.

Crosswise feed

Loosen nut ❷ and set section ❸ of pointer ❹ to a corresponding amount. Then tighten nut ❷ a corresponding amount for 4-hole buttons by the respective procedures below according to the sewing methods

The choice of pattern

When you need to sewing 4-hole buttons ,put down press foot ,

**注意WARNING** 为了防止突然启动造成人身事故，请关掉电源，确认马达确实停止转动后再进行。

To protect against possible personal injury due to abrupt start of the machine ,be sure to the start the following work after turning the power off and ascertaining that the motor is at rest

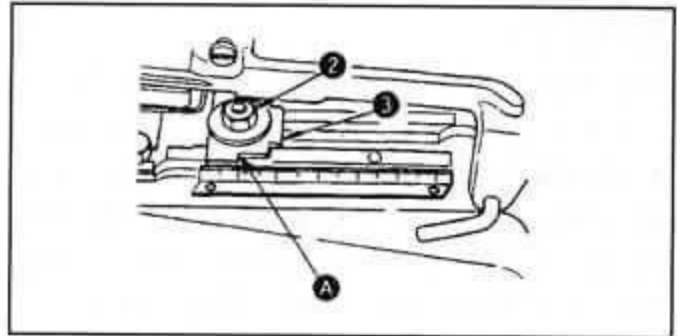
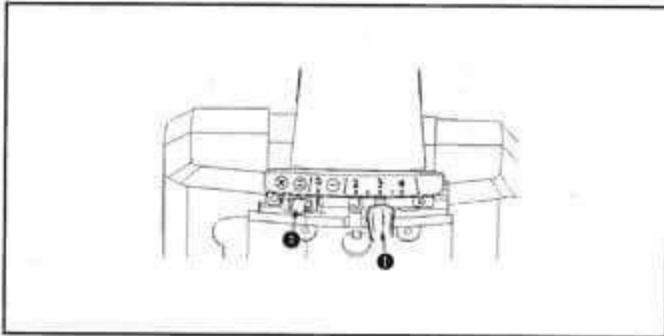

## 十九、切线装置 Automatic thread trimmer

在遮挡位置压脚完全上升到最高位置，切线连接板（前）❶和针板❷槽端面的标准间隙是10~10mm。调整10~11mm时，请放倒缝纫机，卸下防油板，拧松螺母❸（2个），前后移动连接螺丝❹，进行调整。另外拧紧螺母❸时，请注意切线连接头❺应基本保持水平。

When the presser has completely lifted at the stop motion position ,it is the standard that the clearance between thread trimming connecting plate (front) ❶ ,and the end face of the slit of throat plate ❷ is 10 to 11mm.To adjust the aforementioned clearance,tilt the machine herd,remove the oil shield, loosen two nuts ❸ and move connecting screw back or forth.When you tighten nuts ❸,ensure that joint ❺ stays in the horizontal position.

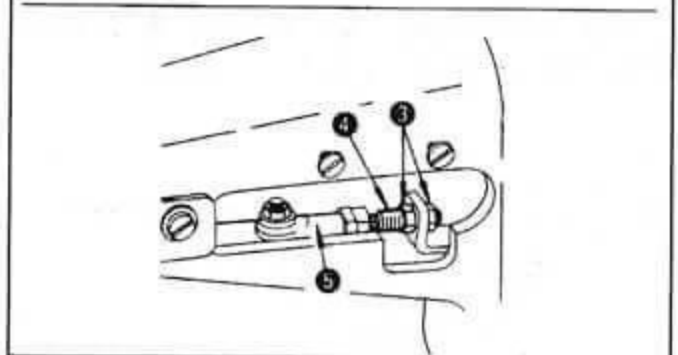
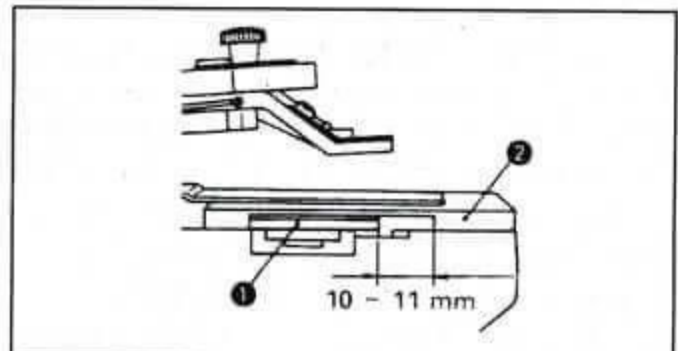

**注意WARNING** 为了防止突然启动造成人身事故，请关掉电源，确认马达确实停止转动后再进行。

To protect against possible personal injury due to abrupt start of the machine ,be sure to the start the following work after turning the power off and ascertaining that the motor is at rest

## 二十、提升拨杆和调节螺丝的间隙

### Clearance between the button clamp lifting lever and the adjusting screw

在遮挡位置请把提升杆①的端面和调节螺丝②的间隙调整为0.5mm，然后用调节螺丝螺母③拧紧固定。

Provide a 0.5mm clearance between the end face of button clamp lifting lever ① and adjusting screw ② at the stop-motion position ③.

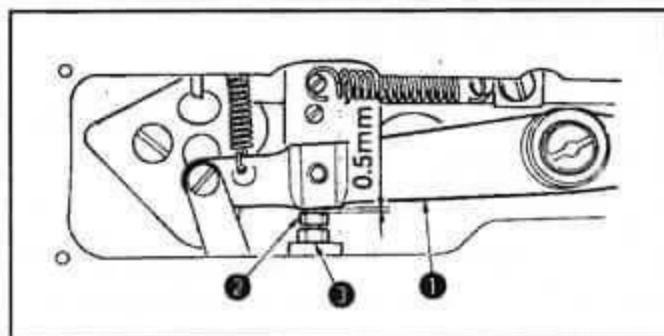

## 二十一、L型提升杆的安装方法 How to set the L-shaped lifting rod

按移动刀反弹簧②、分离垫片③、分离垫④、分离垫片⑤的顺序安装到L型提升杆①上。

在遮挡位置让机臂的鄂部和遮挡缓冲垫片的端部紧密接触，安装时注意不要有松动，然后用螺丝⑥拧紧固定。

Put moving knife push-back spring ②, stop-motion rubber cushion washer ③, stop-motion rubber cushion ④ and stop-motion rubber cushion washer ⑤, in this order, to L-shaped lifting rod ①. Make the jaw of the machine arm come into close contact with the end face of the stop-motion rubber cushion washer at the stop-motion position and set the L-shaped lifting rod without a play. Then tighten it with screw ⑥.

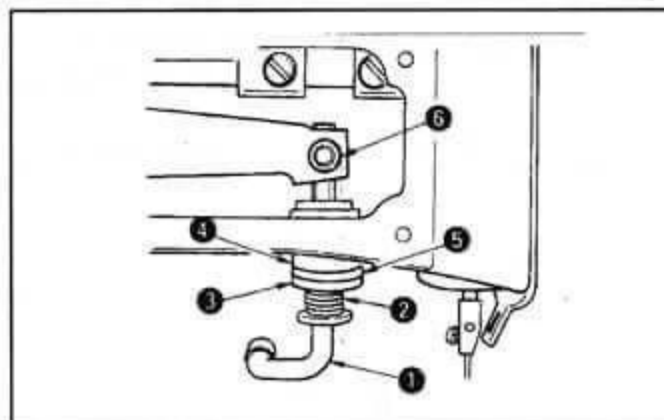

## 二十二、针数 Setting a number of stitches

变换针数时，请打开左侧面护罩，然后用针数调节螺丝和针数调节杆（属于附属品）进行变换

To change the number of stitches, open the left-hand side cover and change the number of stitches using stitch number adjusting screw and stitch number adjusting lever (optional)

8针的调整方法：调整为8针时，请拧松针数调节螺丝①，调整到图示的位置后进行固定。

How to adjust 8 stitches: To make 8 stitches, loosen stitch number adjusting screw ① and fix it to the position as shown in the illustration

16针的调整方法：调整为8针后，请拧松针数调节螺丝①，移动到左侧，然后拧松针数调节螺丝①，调整到图示的位置后进行固定

How to adjust 16 stitches: When stitch number adjusting screw ① being set for "8 stitches" has arrived at the left end, loosen stitch number adjusting screw ① and fix it to the position as shown in the illustration

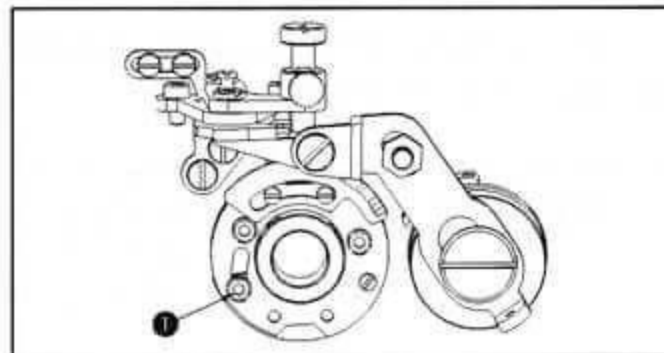
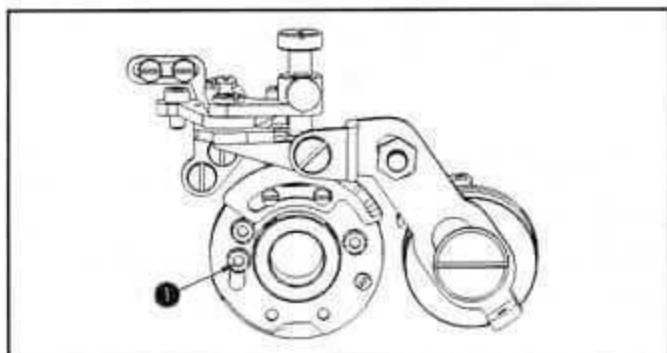

32针的调整方法：在16针的状态安装在大齿轮上的针数调节齿轮凸起②转到下侧后，请用梯形螺丝③（附属品）组装针数调节杆④（附属品）

How to adjust 32 stitches: In the state of 16 stitches ,stitch number adjusting gear roller which is attached to the large gear comes to the lower side ,assemble stitch number adjusting lever ③ (supplied as accessories) using hinge screw ④ (supplied as accessories)

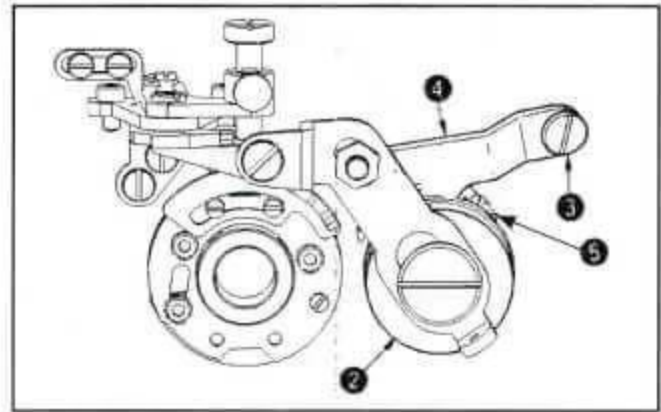

**注意WARNING** 为了防止突然启动造成人身事故，请关掉电源，确认马达确实停止转动后再进行。

To protect against possible personal injure due to abrupt start of the machine ,be sure to the start the following work after turning the power off and ascertaining that the motor is at rest

### 二十三：遮挡位置的调整 Adjusting the position of the stop-motion

缝纫机缝制结束停止后，请把遮挡凸轮的爪①和遮挡钩②调整为相接

Adjust so that claw ① of the stop-motion cam comes in contact with stopmotion hook ② when the sewing machine completes the sewing and stops

注意：更换马达皮带轮，转速变更为1300rpm → 1500rpm时，请一定重新调整遮挡位置。

Caution: When replacing the motor pulley and changing the sewing speed from 1300rpm to 1500rpm, and vice versa, be sure to readjust the position of the stop-motion.

调整方法：遮挡钩碰到遮挡凸轮反弹时（爪①和遮挡钩②之间有间隙时）请拧松遮挡位置调整螺丝③（2处）向A方向转动遮挡调节凸轮④，然后固定遮挡位置调整螺丝③ 遮挡钩碰到遮挡凸轮爪之前停止不动时，请拧松遮挡位置调整螺丝③（2处），向B方向转动遮挡调节凸轮④ 然后固定遮挡位置调整螺丝③。

Adjusting procedure :When the stop-motion hook comes in contact with the stop-motion cam and rebounds ,(when there is a clearance between claw ① and stop-motion hook ②)

loose two stop-motion position adjusting screw ③ turn

Stop-motion adjusting cam ④ in the direction of A,and fix stop-motion position adjusting screws ③ When the stop-motion hook stops before it comes in contact with the stop-motion cam claw Loose two stop-motion position adjusting screws③ turn stop-motion adjusting cam ④ in the direction of B and fix stop-motion position adjusting screws ③

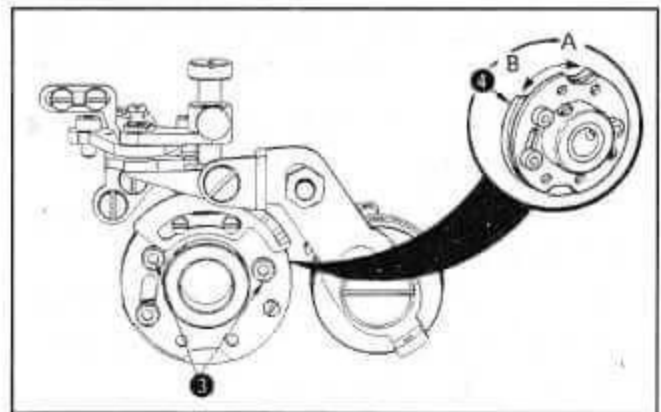
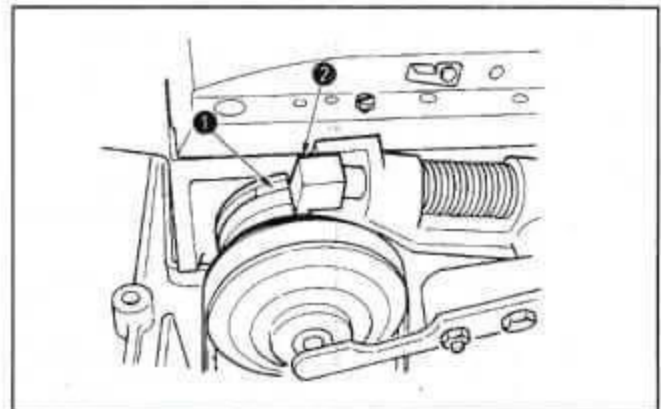

### 二十四：有无结线的变换 Changeover of with/without knot-tying

设定为有结线时，请把结线变换旋钮①压下

To make "with knot-tying ",pull knot-tying changeover knob ① toward the down

设定为无结线时，请把结线变换旋钮①拉起

To make "with knot-tying ",pull knot-tying changeover knob ① toward the up

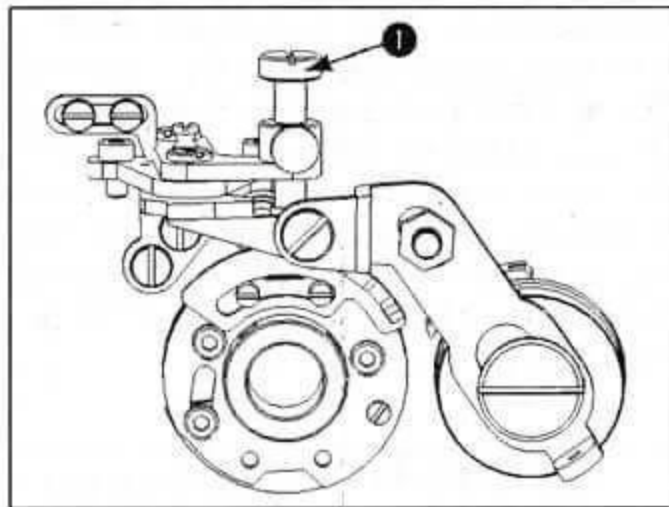
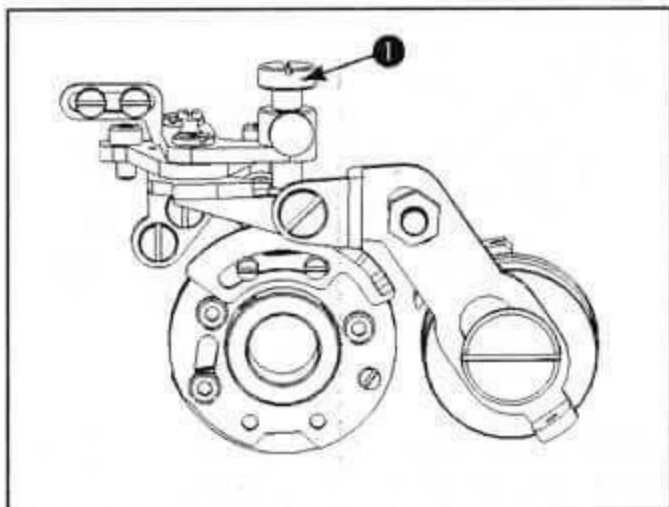

## 二十五、皮带金属部件的连接方式 How to connect the metal fittings of the belt

安装皮带的联接螺丝 ❶ 时，请让螺丝背面突出 1.5~2mm 左右，然后拧紧固定。

Tighten connecting screws ❶ of the belt so that the screws protrude approximately 1.5 to 2mm from the reverse side as the standard.

注意：1.把皮带安装到皮带轮上，盖上侧盖，转动马达后，请确认侧盖和皮带金属器具不相碰。

2.组装皮带时，请注意不要让缝纫机皮带沾附油类物质。

Caution :1.When assembling the belt to the pulley and rotating the motor after closing the side cover ,confirm that the side cover dose not interfere with the metal fitting of the belt.

2. Take care not to allow the belt to be clogged with oil when assembling it

1) 安装各附件时，有的机种不能拆卸抓扣装置 ❶、布压脚下板 ❷

2) 抓扣装置 ❶ 可以卸下安装轴 ❸ 上的拉环，布压脚下板 ❷ 可以卸下固定螺丝 ❹





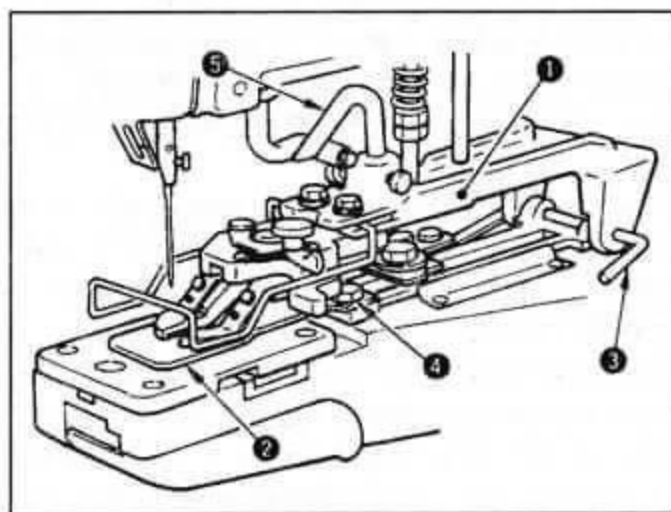
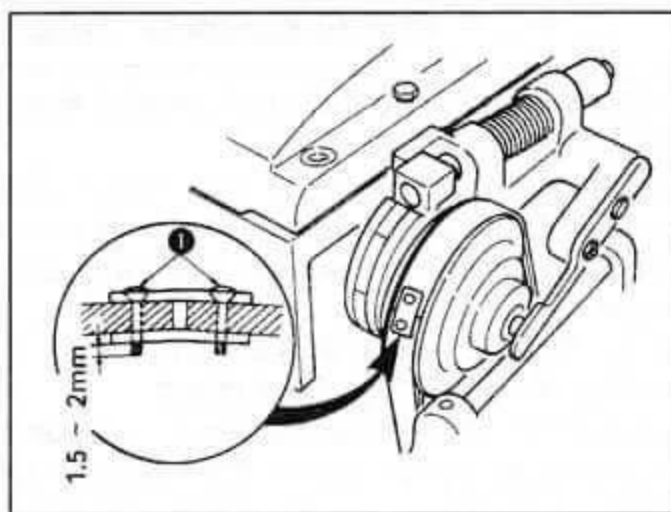

1) In order to install the attachment on the machine ,you may have to remove button clamp mechanism ❶ or feed plate ❷

2) Detach the snap ring from button clamp installing stud ❸ ,and you will be able to move button clamp mechanism assembly ❶ Remove screw ❹ ,and you can remove feed plate ❷

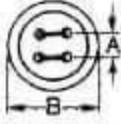
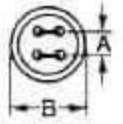
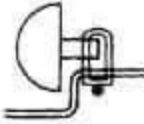

**注意WARNING** 为了防止突然启动造成人身事故，请关掉电源，确认马达确实停止转动后再进行。

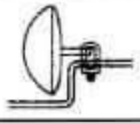
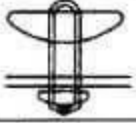
To protect against possible personal injure due to abrupt start of the machine ,be sure to the start the following work after turning the power off and ascertaining that the motor is at rest

用途 Use	平扣用 Flat buttons			子母扣用 Snaps	
	大纽扣 Large-size	中纽扣 Medium-size	一般纽扣 General		
	A	B	C	D	
示意图 Schematic drawing					
备注 Remarks	纽扣尺寸 Button size A: 3 to 5 mm B: $\phi$ 20 to $\phi$ 28 mm	纽扣尺寸 Button size A: 3 to 5 mm B: $\phi$ 12 to $\phi$ 20 mm	柄扣直径 Button diameter 6mm 柄尺寸 厚 Thickness 6.5mm 宽 Width 3, 2.5mm	尺寸 Snap size A: 8mm	
用途 Use	纽扣绕线用 Wrapped-around buttons		金属纽扣用 Metal buttons	力扣用 Stay button	钉标牌 Labels
	第一工序 Frist process	第二工序 Second process	一般 General		
	E	F	G	H	I
示意图 Schematic drawing					
备注 Remarks	钉扣高度 Thread shank height A: 5.5 mm			钉扣高度 Thread shank height A: 5.5 mm	折边宽度 Stitch width 3 to 6.5mm

## 二十六、柄扣（珍珠扣）钉扣附件 Attachments for shank buttons (Pearl buttons)

安装方法:

卸下抓扣装置和布压脚下板，安装上珍珠扣用抓扣装置①，拧松固定螺丝③，前后移动抓脚安装台④，让机针正好落在抓脚②的落针沟中间。同时，让珍珠扣用布压脚下板台⑤正好落在压脚下板⑥的落针沟中间，然后用固定螺丝⑦固定起来。把纽扣压开杆⑧插进机架凸部的孔里，再用固定螺丝⑨固定起来。

(使用方法)

- 1) 拧松固定螺丝⑫，把布压脚下板⑥拉到离抓脚②的左端面0.5~1.0mm的地方，然后拧紧固定螺丝⑫。
- 2) 装上拗扣，拧松固定螺丝⑬和⑭，调整纽扣压脚⑮使其稍稍压住纽扣和中心。
- 3) 调整纽扣压脚⑮的压力时，请拧松推力环固定螺丝，转动推力环⑯调节强度，以便在缝制中不让纽扣移动。
- 4) 打开纽扣压脚，把滑块⑰固定到使用方便的位置。

注意：1. 转动推力环后，不要让转动轴⑱在轴方向产生松动。

2. 抓扣装置上升时，请调整抓扣装置的提升钩⑲和抓扣装置的止动销⑲，让L型提升杆凸块⑲和抓脚安装台④不相碰。

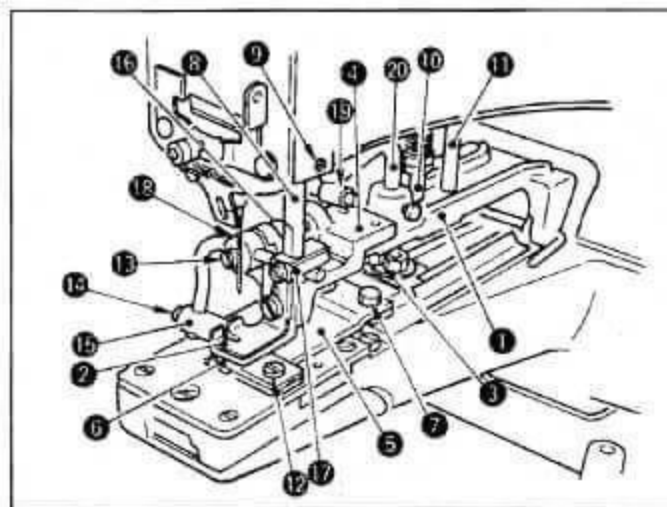

(INSTALLATION)

Remove both the button clamp mechanism assembly and the feed plate from the machine and install attachment ① in place. Loosen screws ③ and adjust button clamp bracket ④ to permit the needle to come down in the middle of the needle slot in shank button adaptor ②. Attach button clamp feed plate ⑤ using screws ⑦ in the way that it permits the needle to come down in the middle of the needle slot in feed plate ⑥. Insert the top end of button clamp stud ⑧ into an opening in the jaw of the machine arm and fasten it by screw ⑨.

**注意WARNING** 为了防止突然启动造成人身事故，请关掉电源，确认马达确实停止转动后再进行。

To protect against possible personal injury due to abrupt start of the machine, be sure to stop the following work after turning the power off and ascertaining that the motor is at rest.

### (ADJUSTMENT AND OPERATION)

- 1) Loosen screw ⑫ .let feed plate ⑥ recede 0.5 to 1.0 mm from the left end of button clamp jaw lever ② and retighten screw ⑫ .
- 2) Set a button in place, loosen screws ⑬ and ⑭ and align shank button holding clamp ⑩ with the center of the button.
- 3) Shank button holding clamp ⑩ must give proper pressure to the button so that the button stays steadily in position while being sewn. Loosen a setscrew in thrust collar ⑪ and rotate the thrust collar until shank button holding clamp ⑩ provides proper pressure.
- 4) You may fix button clamp block ⑦ in a convenient position for operation.

**CAUTION:** 1. When you fix the thrust collar, ensure that button clamp rotating shaft ⑩ does not play axially in its bracket.  
 2. Adjust lifting hook ⑮ and stopper pin ⑯ so that L-shaped lifting rod roller ⑰ does not come in contact with button clamp bracket ④

## 二十七、绕线钉扣第一工序 Attachment for the first process of wrapped-around button

### (安装方法)

用安装螺丝 ② 和导销螺丝 ③ 把绕线用爪 ① 固定到普通的钮扣抓爪部 ① 此时，把钮扣抓爪 安装到钮扣中心左右均等的位置。

### (使用方法)

与钉普通的平扣一样，但是从钮扣到布之间的距离变长了，所以需要调节线调节拨杆把线量弄长。

(参照3-2线调节拨杆的调节 P.4页)

### (INSTALLATION)

Attach wrapped-around button foot ① to the ordinary button clamp jaw levers using screw ② and guide pin screw ③ Align foot ① with the jaw levers so that they permit a button to rest in the middle.

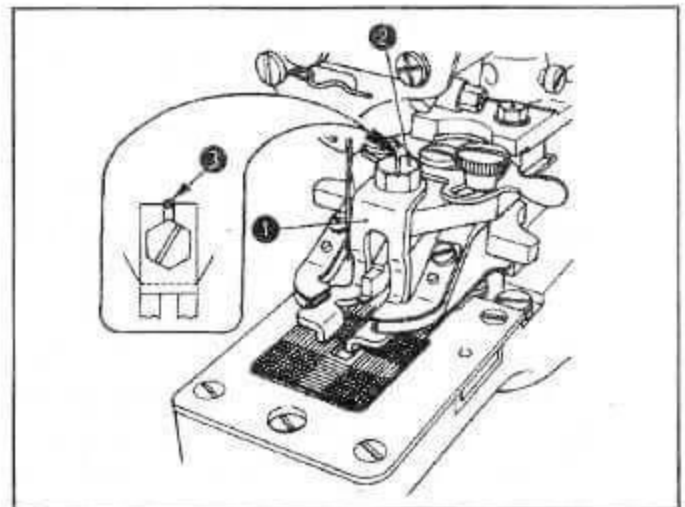

### (ADJUSTMENT AND OPERATION)

Adjustment and operation are almost same as those for the flat buttons, but you must adjust the thread pull-off lever to provide more amount of thread in order to make the thread loose below the button for thread shank formation. (refer to 3-2. Adjustment of the thread thread pull-off lever, P.4)

**注意WARNING** 为了防止突然启动造成人身事故，请关掉电源，确认马达确实停止转动后再进行。

To protect against possible personal injury due to abrupt start of the machine, be sure to the start the following work after turning the power off and ascertaining that the motor is at rest

## 二十八、绕线钉扣第二工序 Attachment for the second process of wrapped-around buttons

### (安装方法)

卸下抓扣装置、压脚压力调节杆和布压脚底板，安装上绕线第2工序用附件 ①。

但是，Z035需要卸掉L型拉杆，按照移动刀反弹弹簧 ③、分离垫片 ⑤、分离垫圈 ④ 的顺序安装杆 ②，确认了完全分离之后，把机架和分离缓冲器 ⑥ 的端面紧紧地安装起来不让它松动。

### (使用方法)

- 1) 拧松安装螺丝 ⑥ 绕线用金属部件 (大) ⑦ 和绕线用金属部件 (小) ⑧ 移动到落针位置的中心，调整绕线长度。
- 2) 放进钮扣，把线从剪头部穿进。
- 3) 把竖送刻度设为0。

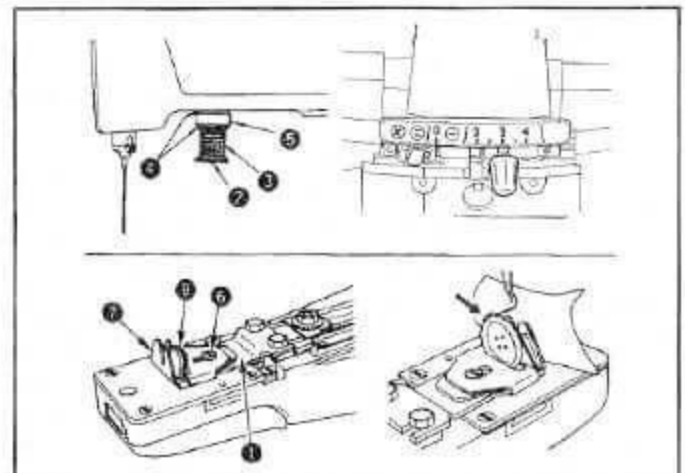

( INSTALLATION )

Remove the button clamp mechanism assembly, button clamp pressure adjusting bar and feed plate from the machine and install attachment for the second process of wrapped-around buttons ❶. When you install a Z035 attachment, you must

Remove also the L-shaped lifting rod. Insert moving knife push-back spring ❸, washer ❹, cushion ❺ and washer ❻ in Spring Guide shaft ❷ in this order. Make certain that the stop-motion Mechanism has completely engaged and install The attachment assembly in place in the way that cushion comes in close contact with the surface of the machine arm without play.

(ADJUSTMENT AND OPERATION)

- 1) Loosen screw ❸ and adjust the thread shank length by moving guide (large) ❷ and guide (small) ❸ in line with the point of needle entry.
- 2) Set a button (tilt it slightly for easy insertion) and pass the thread as the arrow shows.
- 3) Set the lengthwise feed to "0".

**注意WARNING** 为了防止突然启动造成人身事故，请关掉电源，确认马达确实停止转动后再进行。

To protect against possible personal injury due to abrupt start of the machine, be sure to start the following work after turning the power off and ascertaining that the motor is at rest

## 二十九、钉子母扣 Attachment for snaps

(安装方法)

卸下抓扣装置和布压脚下板，横送布刻度和竖送布刻度设定为4mm以后，安装子母扣用下布压板❶，让针均匀地落到四角孔里。然后，在子母扣抓脚抓住子母扣的状态，安装上子母扣抓扣装置❷，让机针正确地落到扣孔里。如果落针不正确的话，请拧松六角螺丝❸进行调整。最后，请确认下布压板❶的凸形和子母扣用纽扣导爪❹下面的凹形是否完全一致。

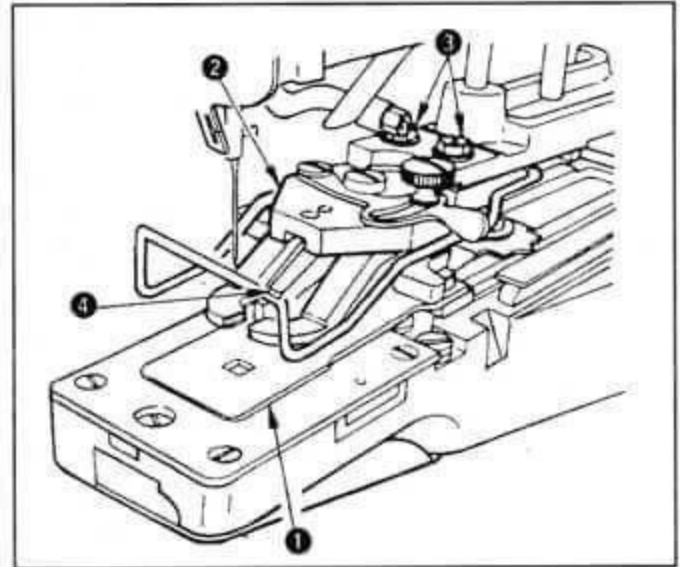

( INSTALLATION )

Remove the button clamp mechanism assembly and the feed plate. Set both the crosswise feed and lengthwise feed graduated plates to "4mm". Install snap clamp feed plate ❶ in the way that the

needle drops evenly at four corners of its square opening. Install snap attachment assembly ❷ on the machine, place a snap on the snap clamp jaw levers and make sure that the needle drops accurately in each hole in the snap. if necessary. Loosen hex head screws ❸ and Adjust the position accurately. Lastly, make sure that the concave section on the bottom face of snap clamp slide guide ❹ accurately matches the convex section on snap clamp feed plate ❶.

**注意WARNING** 为了防止突然启动造成人身事故，请关掉电源，确认马达确实停止转动后再进行。

To protect against possible personal injury due to abrupt start of the machine, be sure to start the following work after turning the power off and ascertaining that the motor is at rest

## 三十、钉金属扣 Attachment for metal buttons

(安装方法)

卸下抓扣装置和布压脚下板，安装金属扣用抓扣装置❶，拧松固定螺丝帽❷，前后移动抓爪安装台❸，让机针正好落在抓爪❹的落针沟的中间。另外，用固定螺丝❺固定金属扣用布压脚下板❻，让机针正好落在压脚下板❻的落针槽中。把纽扣压开杆❿插进机架头部的孔里，然后用固定螺丝⓫拧紧固定。

(使用方法)

- 1) 拧紧固定螺丝 ⑩, 把布压脚下板 ⑥ 从抓爪 ② 的左端面拉进1.0~1.5mm, 然后拧紧固定螺丝 ⑩.
  - 2) 安放钮扣, 拧松固定螺丝 ⑪ 和 ⑫, 让钮扣压脚 ⑬ 正好压住钮扣的中心.
  - 3) 拧松固定螺丝, 转动轴环 ⑭ 进行调整, 让钮扣压脚 ⑬ 的压力在缝制中不让钮扣移动.
  - 4) 把钮扣压脚打开凸轮 ⑮ 移动到使用方便的位置固定起来.
1. 转动轴环时, 旋转轴 ⑯ 在轴方向不能有松动.
  2. 抓扣装置上升时, 请调整抓扣装置的提升钩 ⑰ 和抓扣装置止动销 ⑱, 让L型提升杆凸块 ⑲ 和抓脚安装台 ④ 不相碰.

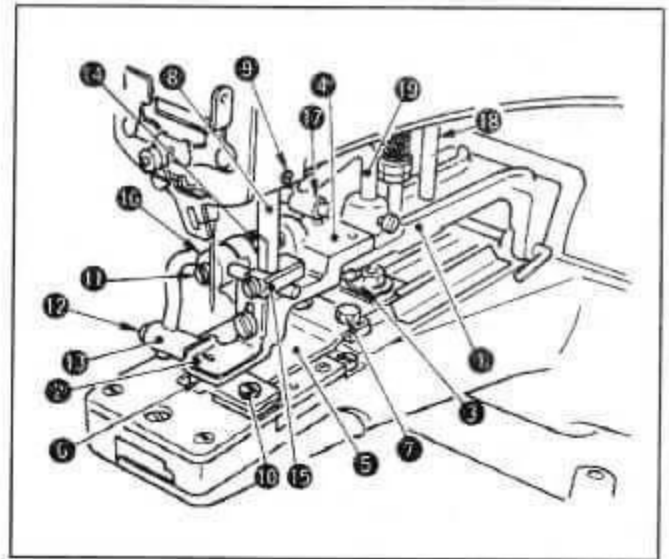

(INSTALLATION)

Remove both the button clamp mechanism assembly and the feed plate from the machine and install attachment ① in place. Loosen screws ③ and adjust button clamp bracket ④ to permit the needle to come down in the middle of the needle slot in metal button adaptor ②. Attach button clamp feed plate ⑤ using screws ⑦ in the way that it permits the needle to come down in the middle of the needle slot in feed plate. Insert the top end of button clamp stud ⑧ into an opening in the jaw of the machine arm and fasten it by screw ⑨.

(ADJUSTMENT AND OPERATION)

- 1) Loosen screw ⑩, let feed plate ⑤ recede 1.0 to 1.5mm from the left end of button clamp jaw lever ② and retighten screw ⑩.
- 2) Set a button in place, loosen screws ⑪ and ⑫ and align metal button holding clamp ⑬ with the center of the button.
- 3) metal button holding clamp ⑬ must give proper pressure to the button so that the button stays steadily in position while being sewn. Loosen a setscrew in thrust collar ⑭ and rotate the thrust collar until metal button holding clamp ⑬ provides proper pressure.
- 4) You may fix button clamp block ⑮ in a convenient position for operation.

CAUTION: 1. When you fix the thrust collar, ensure that button clamp rotating shaft ⑯ does not play axially in its bracket.  
2. Adjust lifting hook ⑰ and stopper pin ⑱ so that L-shaped lifting rod roller ⑲ does not come in contact with button clamp bracket ④.

**注意WARNING** 为了防止突然启动造成人身事故, 请关掉电源, 确认马达确实停止转动后再进行。

To protect against possible personal injury due to abrupt start of the machine, be sure to the start the following work after turning the power off and ascertaining that the motor is at rest

**三十一、马达皮带轮和皮带 Motor pulley and belt**

- 1) 马达使用单相、输入功率200W (1/4马力) 的通用马达。
- 2) 请使用V型皮带。
- 3) 马达皮带轮和缝纫机转速的关系如下表所示。

HZ	Rpm	电机带轮图号 Motor pulley part Number	
50	1500		φ 76
	1300		φ 64.5
60	1500		φ 64.5
	1300		φ 57

马达的转动方向，从马达皮带轮侧看是逆时针转动。请注意不要让皮带轮逆转。

更换马达皮带轮，转速变更为1300rpm 1500rpm时，请一定重新调整遮挡位置。(参照3-14，遮挡位置的调整P.8)

1)For this machine a single-phase or 3-phase 200 watts (1/4HP)induction motor is used.

2)Use a V belt.

3)The sewing speed depends on the diameter of the motor pulley as listed below;

The rotating direction of motor is counterclockwise when viewed from the motor pulley side.

Be careful not to rotate in reverse direction.

When replacing the motor pulley and changing the sewing speed from 1300rpm to1500rpm and vice versa,be sure to re-adjust the position of the stop-motion.(Refer to "Adjusting the position of the stop-motion",p.8.)

故障	原因	对策
1.断线	1.靠线动作不良. 2.紧线拨杆调整不良. 3.第二线张力盘的同步不好. 4.抓扣装置的上升量太高. 5.拨针器压线,拨针器调整不良.(间隙小) 6.机针没有落到钮扣的中心. 7.针与扣眼相比太粗.	调整靠线器的前后左右同步 调整紧线拨杆. 提早线张力盘浮起同步. 把抓脚上升量调整为8mm. 调整拨针器摆动滑块. 用抓脚安装台调整.. 换为细针.
2.始缝时形成不了缝迹,中途开始出缝迹.	1.线调详拨杆的调整不良. 2.面板线张力太大.	调整线张力拨杆摆动轴. 减弱面板线张力.
3.紧线不良	1.靠线动作不良. 2.第二线张力盘的同步不好, 3.第二线张力盘的张力不良. 4.机针没有落到钮扣的中心. 5.布压脚压力不良.	调整靠线器的前后左右同步. 稍稍推迟线张力盘浮起同步时间. 用第二线张力盘调整. 用抓脚安装台调整. 调整布压脚压力.
4.最终针的加固缝紧线弱.	1.紧线拨杆调整不良. 2.结线板的同步不良.  3.拨针器调整不良.(间隙过大)	调整紧线拨杆. 提早结线板的同步时间.(调整结线打结)  用拨针器摆动滑块调整.
5.钮扣上第一针的线出得太长	线张力拨杆调整不良.	调整线张力拨杆摆动轴
6.分离时切线不良	1.第二线张力盘的同步不好 2.机针碰到钮扣孔 3.拨针器压线不良 4.布压脚压力太大	稍微推迟线张力盘浮起同步,使紧线变好. 调整落针 调整拨针器摆动滑块. 用布压脚压力调整螺母进行调整.
7.切线不断	1.移动刀分线爪不能把布侧的线确实分开. 2.机针没有落到钮扣的中心. 3.最后落针跳针 4.移动刀分线爪高度不良	调整移动刀位置 用抓脚安装台调整. 调整弯针 调整移动刀分线爪的高度.
8.面线和底线2根都断线	1.移动刀位置不良. 2.移动刀分线爪高度不良.	调整分离时移动刀的位置. 调整移动刀分线爪的高度
9.切线后布里侧线出得太长	1.线移动刀切线同步不良 2.抓扣装置上升量过大.	调整移动刀位置 把抓脚上升量调整为8mm
10.切断后布背面出线长度有长有短	1.移动刀位置不正确 2.抓扣装置的上升量过高	调整分离时移动刀的位置.(10~11mm)  把抓脚上升量调整为8mm

TROUBLES	CAUSES	CORRECTIVE MEASURES
1.Thread breakage	<p>1.The yoke slide does not move in the correct way.</p> <p>2.The tension lever has been improperly adjusted.</p> <p>3.The thread tension post No.2 fails to release the thread at correct timing.</p> <p>4.Lifting amount of the button clamp jaw unit is excessive.</p> <p>5.The thread nipper catches the thread The nipper has been improperly adjusted. (The clearance is too small.)</p> <p>6.The needle does not enter the center of the holes in the button,</p> <p>7.The needle is too thick for the diameter of the hole in the button.</p>	<p>Adjust the timing of forward,backward and sideways of the yoke slide.</p> <p>Properly adjust the tension lever.</p> <p>Make the thread release timing slightly earlier.</p> <p>Adjust the lifting amount of the button clamp jaw lever to 8 mm.</p> <p>Adjust the position of the nipper bar block.</p> <p>Adjust the button clamp jaw lever holder.</p> <p>Replace the needle the needle by a thinner one.</p>
2.The machine forms a seam after it has run for a while instead of forming it from the start of sewing.	<p>1.The thread pull-off lever has been improperly adjusted,</p> <p>2.Tension of the thread tension guide on the face plate is excessive.</p>	<p>Adjust the thread tension guide on the face plate so that it provides a lower tension.</p> <p>Properly adjust the tension lever.</p>
3.Buttons are not sewn tightly	<p>1.The yoke slide does not move in the correct way.</p> <p>2.The thread post No.2 fails to release the thread at correct timing.</p> <p>3.The thread post No.2 does not give sufficient tension.</p> <p>4.The needle does not enter the center the holes in the button.</p> <p>5.The work pressing force is too high or too low.</p>	<p>Adjust the timing of the motion of the yoke slide at each end.</p> <p>Make the thread release timing slightly later.</p> <p>Tighten the tension nut of tension post No.2.</p> <p>Adjust the button clamp jaw lever holder.</p> <p>Adjust the work pressing force properly.</p>
4.The last back-tack stitch is poorly tensed	<p>1.The tension lever has been improperly adjusted.</p> <p>2.Timing of the knot-tying plate is incorrect.</p> <p>3.The nipper has been improperly adjusted. (The clearance is too large.)</p>	<p>Properly adjust the tension lever.</p> <p>Advance the timing of the knot-tying plate. (Adjustment of the knot-tying notch)</p> <p>Adjust the nipper with the nipper bar block.</p>
5.The first stitch trails relatively long thread from the right side of the button	<p>The thread pull-off lever does not work properly.</p>	<p>Adjust the thread pull-off lever by the nipper bar block(rear)</p>
6.Thread trimming failure in the state of stop-motion	<p>1.The thread tension post No.2 fails to release the thread at correct timing.</p> <p>2.The needle hits the edge of the holes in the button.</p> <p>3.The thread nipper fails to press the thread.</p> <p>4.The work pressing force is too high.</p>	<p>Make the thread release timing slightly later to give more tension to the stitches.</p> <p>Adjust the button clamp jaw lever holder.</p> <p>Adjust the nipper bar block.</p> <p>Adjust the work pressing force by the pressure adjusting nut.</p>
7.Thread trimming failure	<p>1.The moving knife does not separate the thread on the fabric with its separation nail.</p> <p>2.The needle does not enter the center of the holes in the button.</p> <p>3.The last stitch skips.</p> <p>4.The moving knife thread separation nail is too high or too low.</p>	<p>Adjust the position of the moving knife.</p> <p>Adjust the button clamp jaw lever holders.</p> <p>Adjust the looper.</p> <p>Adjust the height of the moving knife thread separation nail</p>
8.The needle thread is cut in two places on the wrong side of the fabric	<p>1.The moving knife is set in wrong place.</p> <p>2.The moving knife thread separation nail is too high or too low.</p>	<p>Adjust the position of the moving knife when the machine is in the stop-motion state.</p> <p>Adjust the height of the thread separation nail.</p>

高速单针筒式底板锁式线迹加固缝纫机  
High Speed 1-needle Cylinder Bed Lockstitch  
Bar Taching Industrial Sewing Machine

零件目录

PARTS LIST

目 录

CONTENTS

一 标准型零件目录部分

1. 钮夹部件.....	23
BUTTON CLAMP MECHANISM COMPONENTS	
2. 机壳底座部件.....	25
ARM & MISCELLANEOUS COVERS COMPONENTS	
3. 旋勾轴相关部件.....	27
LOOPER SHAFT MECHANISM COMPONENTS	
4. 过线松线相关部件.....	29
NIPPER & THREAD TENSION PARTS COMPONENTS	
5. 送料相关部件.....	32
FEED PLATE COMPONENTS	
6. 钮夹提升相关部件.....	34
BUTTON CLAMP LIFTER COMPONENTS	
7. 驱动轴相关部件.....	37
NEEDLE DRIVING PULLERY SHAFT COMPONENT	
8. 针杆驱动机构部件.....	38
NEEDLE BAR DRIVING MECHANISM COMPONENTS	
9. 止动机构部件.....	39
STOP MOTION MECHANISM COMPONENTS	
10. 针数调节相关部件.....	40
STITCH SELECTING PARTS COMPONENTS	
11. 打结相关部件.....	42
THREAD BIND NOTCH COMPONENTS	
12. 线架组件.....	43
THREAD STAND COMPONENTS	
13. 附件部分.....	44
ACCESSORIE PARTS COMPONENTS	

一、钮夹部件

BUTTON CLAMP MECHANISM COMPONENTS

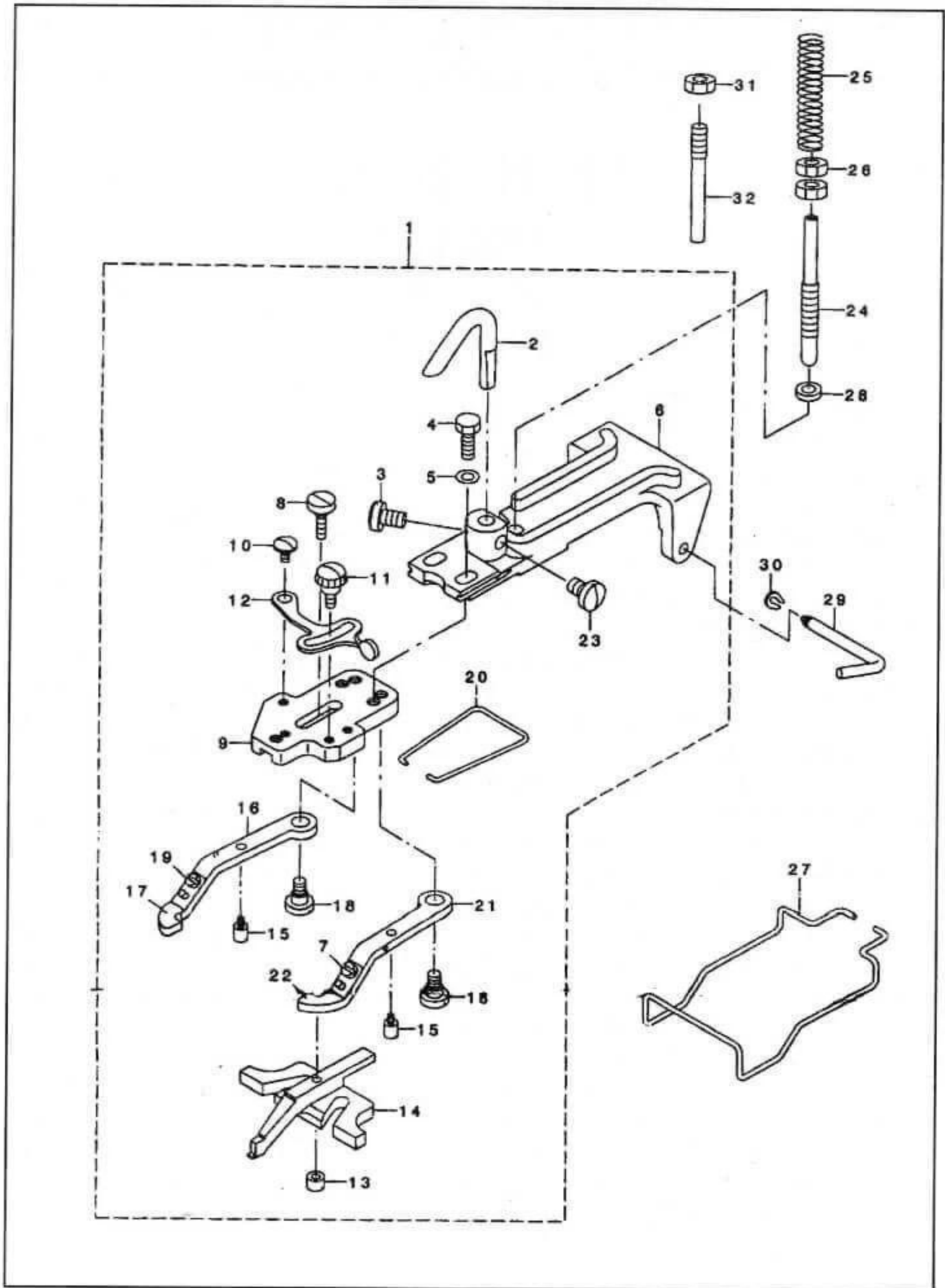

REF No 序号	PART NO 件号	DESCRIPTION 名称	Q'TY 数量	
1	85.1-00	钮夹组件	PICK-UP DEVICE ASM	1
2	85.1-1	抬压臂提升钩	BUTTON CLAMP LIFTING HOOK	1
3	95.7-12	抬压臂提升钩紧固螺钉	SCREW 15/64"X28 L=9	2
4	85.1-2	钮夹底座安装螺钉	SCREW 3/16"X32 L=13.5	2
5	95.10-7	钮夹底座安装螺钉垫片	WASHER 5X10.5X1	1
6	85.1-3	压臂	BUTTON CLAMP HOLDER	1
7	90.3-13-5	钮夹板弹簧安装螺钉	SCREW 9/64"X40 L=13.5	1
8	85.1-4	钮夹后安装段螺钉	HINGE SCREW D=5.5 H=3	1
9	85.1-5	钮夹底座	JAW LEVER HOLDER	1
10	85.1-6	钮夹尺寸调节板段螺钉	HINGE SCREW D=5.5 H=1.8	1
11	85.1-7	钮夹尺寸调节板紧固螺钉	CLAMP SCREW A	1
12	85.1-8	钮夹尺寸调节板	SNAP FASTENER CLAMP STOP LEVER	1
13	85.1-9	钮夹后安装段螺钉螺母	NUT	1
14	85.1-10	钮夹后	BUTTON CLAMP SLIDE	2
15	85.1-11	钮夹止动销	BUTTON CLAMP STOP PIN	1
16	85.1-12	钮夹L	BUTTON CLAMP LEVER JAM (LEFT)	1
17	85.1-13	钮夹板弹簧L	BUTTON HOLDING SPRING ,LEFT	2
18	90.4-19	钮夹连接段螺钉	HINGE SCREW D=6.35 H=3.9	1
19	90.3-13-5	钮夹板弹簧安装螺钉	SCREW 9/64"X40 L=3.5	1
20	85.1-14	钮夹弹簧	BUTTON CLAMP SPRING	1
21	85.1-15	钮夹R	BUTTON CLAMP LEVER JAM (RIGHT)	1
22	85.1-16	钮夹板弹簧R	BUTTON HOLDING SPRING ,RIGHT	1
23	95.7-12	抬压臂提升钩定位螺钉	SCREW 15/64"X28 L=9	1
24	85.1-17	钮夹压力调节杆	BUTTON CLAMP PRESSURE ADJUSTING	1
25	85.1-18	钮夹压力调节弹簧	PRESSURE ADJUSTING SPRING	2
26	95.13-6	钮夹压力调节杆螺母	NUT M6	1
27	85.1-19	护指器	FINGER GUARD	1
28	85.1-20	钮夹压力调节杆垫	SPRING HOLDING SPRING	1
29	85.1-21	压臂轴	HINGER PIN	1
30		压臂轴异形卡簧	SNAP RING	1
31	95.13-6	压臂止动销钉螺母	NUT M6	1
32	85.1-22	压臂止动销	PICK-UP DEVICE STOPPER PIN	

## 二、机壳底座部件

## ARM & MISCELLANEOUS COVERS COMPONENTS

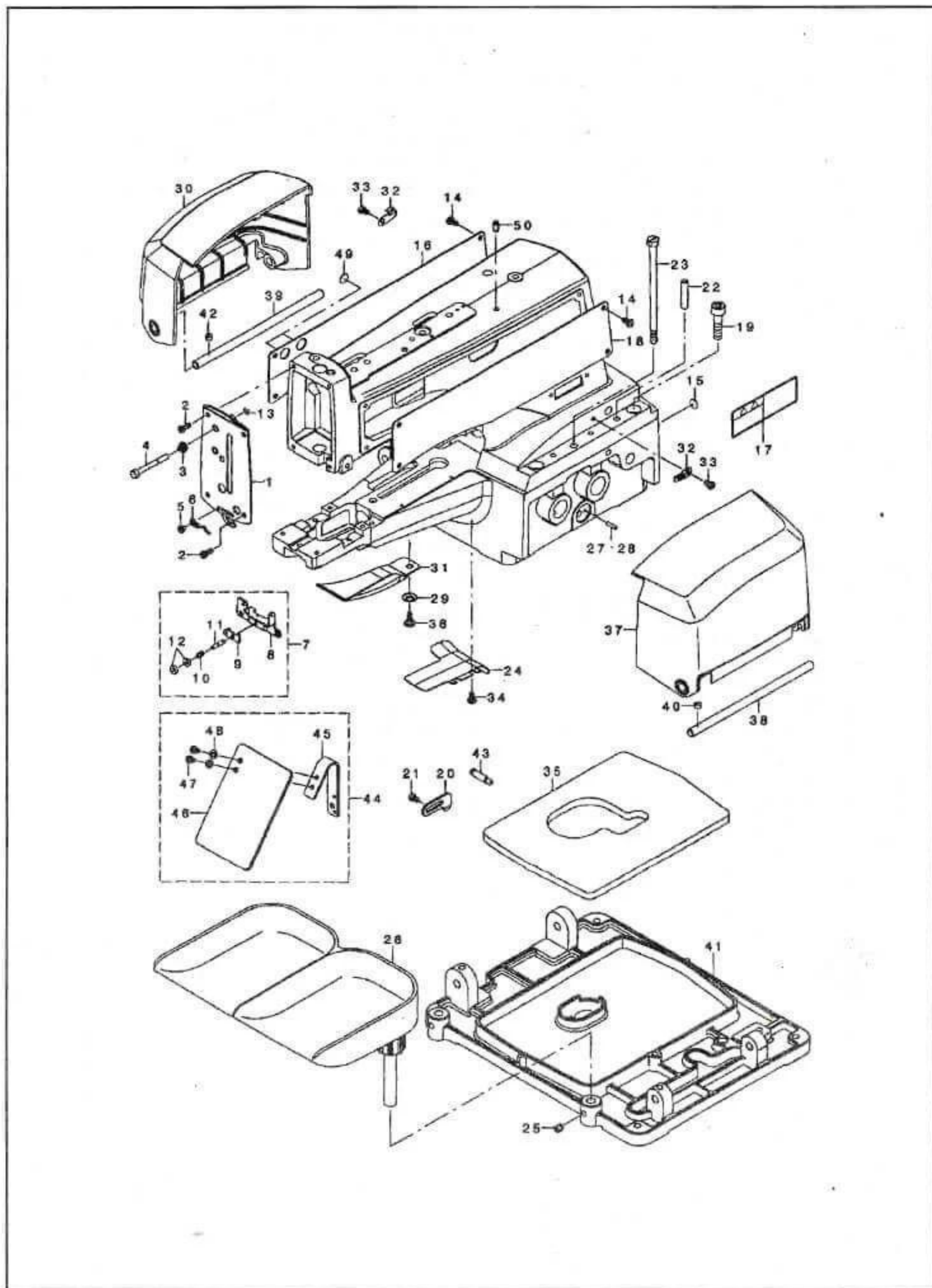

REF No 序号	PART NO 件号	DESCRIPTION 名称	Q'TY 数量	
1	85.2-3	面板组件	FACE PLATE COMPL.	1
2	85.2-4	面板螺钉	SCREW	4
3	85.2-5	松线按钮销弹簧	TENSION SPRING	1
4	85.2-6	松线按钮销	NIPPER RELEASING STUD	1
5	85.2-7	过线钩No4安装螺钉	SCREW	1
6	85.2-8	过线钩No4	THREAD GUIDE NO.4	1
7	85.2-9	压线板组件No3	THREAD TENSION NO.3 ASM.	1
8	85.2-9-1	压线板座No3	TENSION ADJUSTING BASE NO.3	1
9	85.2-9-2	压线板No3	THREAD PRESSER PLATE	1
10	85.2-9-3	压线板弹簧No3	TENSION SPRING B	1
11	85.2-9-4	压线板销No3	THREAD TENSION STUD	1
12	85.2-9-5	压线调节螺母	THREAD TENSION NUT	2
13		松线按钮销E形卡簧3.2	E-RING 3.2	1
14	85.2-4	左右侧盖螺钉	SCREW	8
15	85.2-34	橡皮塞	RUBBER PLUG	1
16	85.2-11	机头左侧盖	SIDE COVER RIGHT	1
17		注意标贴	SAFETY LABEL	1
18	85.2-13	机头右侧盖	SIDE COVER LEFT	1
19		拼装螺钉	SCREW M8 L=30	4
20	85.2-14	止动块	STOPPER	1
21	85.2-15	止动块螺钉	SCREW M5L=8	2
22	85.2-35	拼装定位销	GUIDE PIN	2
23	85.2-16	机壳锁紧螺钉	SET SCREW	1
24	85.2-17	底板挡油板	BED OIL SHIELD	1
25	85.2-18	钮口盘支紧螺钉	SCREW	1
26	85.2-19	钮口盘组件	BUTTON TRAY ASM	1
27		送布凸轮位置定位销A	CAN INDICATING PIN A	2
29	85.2-20	弯勾盖安装段螺钉弹簧垫片	SPRING WASHER 6.5x14x17	2
30	85.2-21	底板侧盖(左)	SIDE COVER LEFT	1
31	85.2-22	弯勾盖	LOOPER COVER	1
32	85.2-23	侧盖止动板弹簧	SIDE COVER SPRING	1
33	85.2-24	侧盖止动板弹簧螺钉	SCREW M4 L=6	2
34	85.2-4	底板挡油板螺钉	SCREW	2
35	85.2-25	底板油毡	OIL DRIP FELT	1
36	85.2-26	弯勾盖安装段螺钉	SHOULDER SCREW D=6 H=2.7	1
37	85.2-27	底板侧盖(右)	SIDE COVER RIGHT	1
38	85.2-28	底板侧盖(右)铰链轴	SIDE COVER HINGE SHAFT RIGHT	2
39	85.2-29	底板侧盖(左)铰链轴	SIDE COVER HIGE SHAFT LEFT	1
40	85.2-30	底板侧盖(右)铰链轴支紧螺钉	SCREW M6 L=6	1
41	85.2-31	底座	MACHINE SUB BASE	1
42	85.2-30	底板侧盖(左)铰链轴支紧螺钉	SCREW M6 L=6	1
43	85.2-32	下剪线作动板连杆弹簧挂钩	SUSPENSION SCREW	1
44	85.2-33	护眼板组件	ASSY SAFETY PLATE	1
45	85.2-33-1	护眼板支架	SAFETY PLATE INSTANLLING BASE	1
46	90.1-46-1	护眼板	SAFETY PLATE	1
47	85.2-33-2	护眼板安装螺钉	SCREW M4 L=6	2
48	85.2-33-3	护眼板安装螺钉垫片	WASHER M4	2
49	35.1-4	机头左侧盖橡皮塞	RUBBER PLUG D=12.5 L=4	2
50		开口销	SPRING PIN 5X10	1

### 三、旋钩轴相关部件

### LOOPER SHAFT MECHANISM COMPONENTS

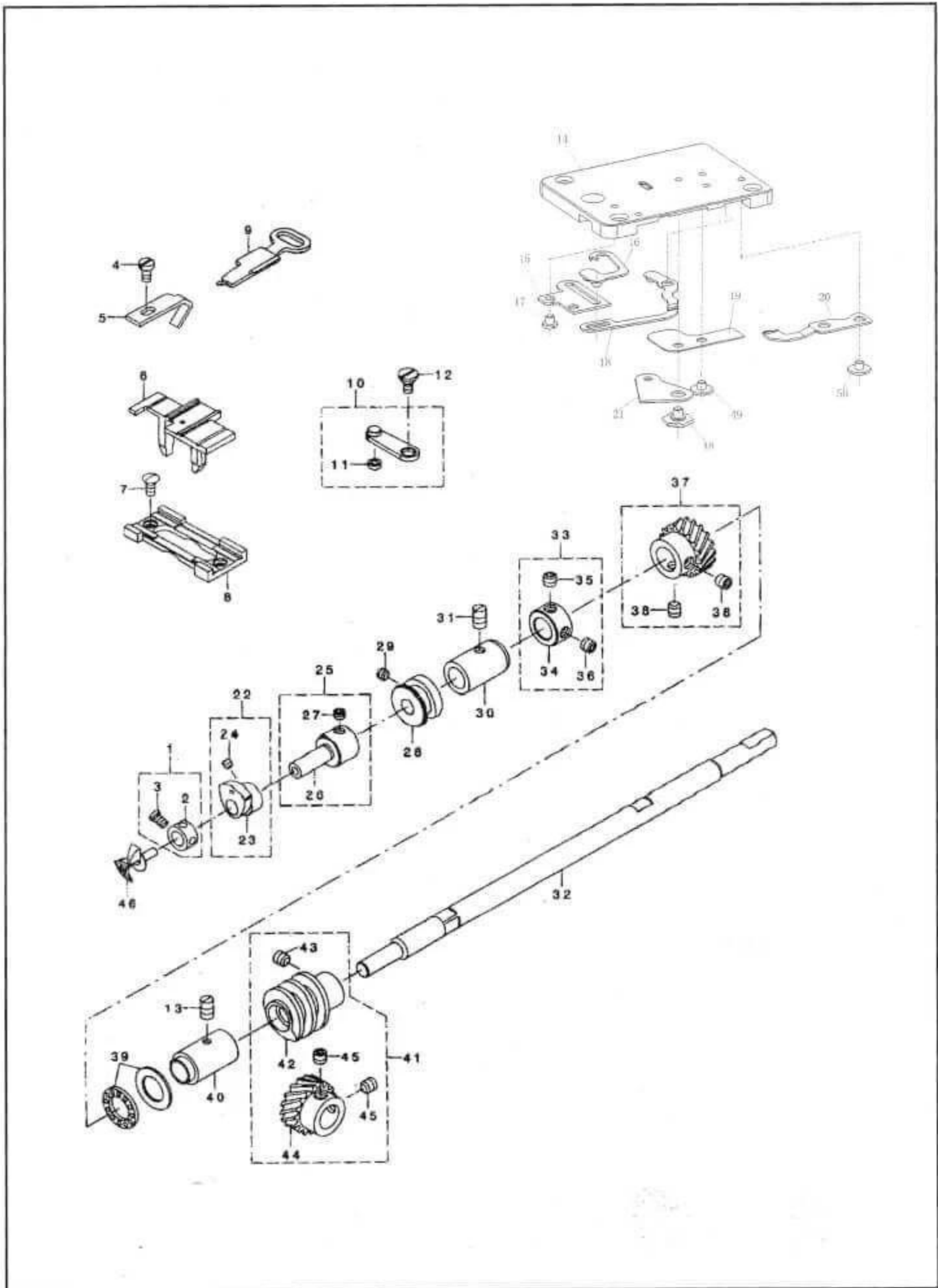

REF No 序号	PART NO 件号	DESCRIPTION 名称	Q'TY 数量	
1	85.3-1-00	弯针紧圈组件	THRUST COLLAR ASM	1
2	85.3-1	弯针紧圈	THRUST COLLAR D=7.94 W=7	1
3	90.4-14	弯针紧圈螺钉	SCREW 9/64"X40 L=6.1	1
4	85.3-2	护针板螺钉	SCREW	1
5	85.3-3	护针板	NEEDLE GUARD	1
6	85.3-4	送料器导向台	POSITIONING FINGER YOKE SLIDE	1
7	85.3-5	送线器底座安装螺钉	SCREW M4 L=9	2
8	85.3-6	送线器底座	YOKE SLIDE INSERT	1
9	85.3-7	送线器	YOKE SLIDE	1
10	85.3-8	送线器铰链组件	ASSY LOOP POSITIONING FINGER L	1
11	85.3-8-2	送线器铰链滚轮	LOOP POSITIONING FINGER CAM RO	1
12	85.3-10	送线器铰链安装段螺钉	HINGE SCREW D=6.35 H=2.4	1
13	85.3-11	下轴后轴套支紧螺钉	SCREW	1
14	85.3-12-1	针板	THROAT PLATE	1
15	85.3-12-8	滚动线板导轨	THREAD BIND PLATE GUIDE	1
16	85.3-12-3	滚动线板	THREAD BIND PLATE ASM	1
17	85.3-12-9	滚动线板导轨安装螺钉	SCREW	1
18	85.3-12-10	连杆	LINK	1
19	85.3-12-3	滚动线板支撑板	THREAD BIND SUPPORT PLATE	2
20	85.3-12-4	固定刀	COUNTER KNIFE	1
21	85.3-12-6	移动刀	MOVING KNIFE	1
22	85.3-13-00	履角凸轮组件	ASSY LOOP POSITIONING FINGER C	1
23	85.3-13	履角凸轮	LOOP POSITIONING FINGER CAM	1
24	40.3-30	履角凸轮螺钉	SCREW 11/64"X40 L=3.5	2
25	85.3-14-00	旋勾轴组件	ASSY CAM AND LOOPER SLEEVE	1
26	85.3-14	旋勾轴	CAM AND LOOPER SLEEVE	1
27	43.5-26	旋勾轴螺钉	SCREW 15/64"X28 L=4.0	2
28	85.3-15	带槽凸轮	LOOP POSITIONING FINGER CAM RE	1
29	40.2-34	带槽凸轮螺钉	SCREW 11/64"X40L=2.8	2
30	85.3-16	下轴前套	LOOPER SHAFT BUSHING FRONT	1
31	85.3-11	下轴前套支紧螺钉	SCREW	1
32	85.3-17	下轴	LOOPER SHAFT	1
33	85.3-18-00	下轴紧圈组件	THRUST COLLER ASM	1
34	85.3-18	下轴紧圈	THRUST COLLER D=11.11 W=10	1
35	95.3-13	下轴紧圈螺钉	SCREW 1/4"X40 L=5	1
36	85.3-19-00	下轴螺旋齿轮组件	SCREW 1/4"X40 L=5	1
37	85.3-19	下轴螺旋齿轮	LOOPER SHAFT DRIVEN GEAR ASM	1
38	90.2-36	下轴螺旋齿轮螺钉	SCREW 1/4"X40 L=6	2
39	85.3-20	下轴后轴承组件	THRUST BALL BEARING	1
40	85.3-21	下轴后套	LOOPER SHAFT BUSHING REAR	1
41	85.3-22-00	蜗杆组件	WORM WHEEL ASM	1
42	85.3-22	蜗杆	WORM	1
43	85.3-23	蜗杆螺钉	SCREW 1/4"X40 L=7.0	2
44	85.3-24	蜗轮	CAM SHAFT DRIVEN GEAR	1
45	90.2-36	蜗轮螺钉	SCREW 1/4"X40 L=6	2
46	85.3-25	弯勾	LOOPER	1
47	85.3-26	针板安装螺钉	SCREW M4 L=9	3
48	85.3-12-7	移动刀安装段螺钉	HINGE SCREW D=6 H=0.85	1
49	85.3-12-5	固定刀安装螺钉	SCREW	3

#### 四、过线松线相关部件

#### NIPPER & THREAD TENSION PARTS COMPONENTS

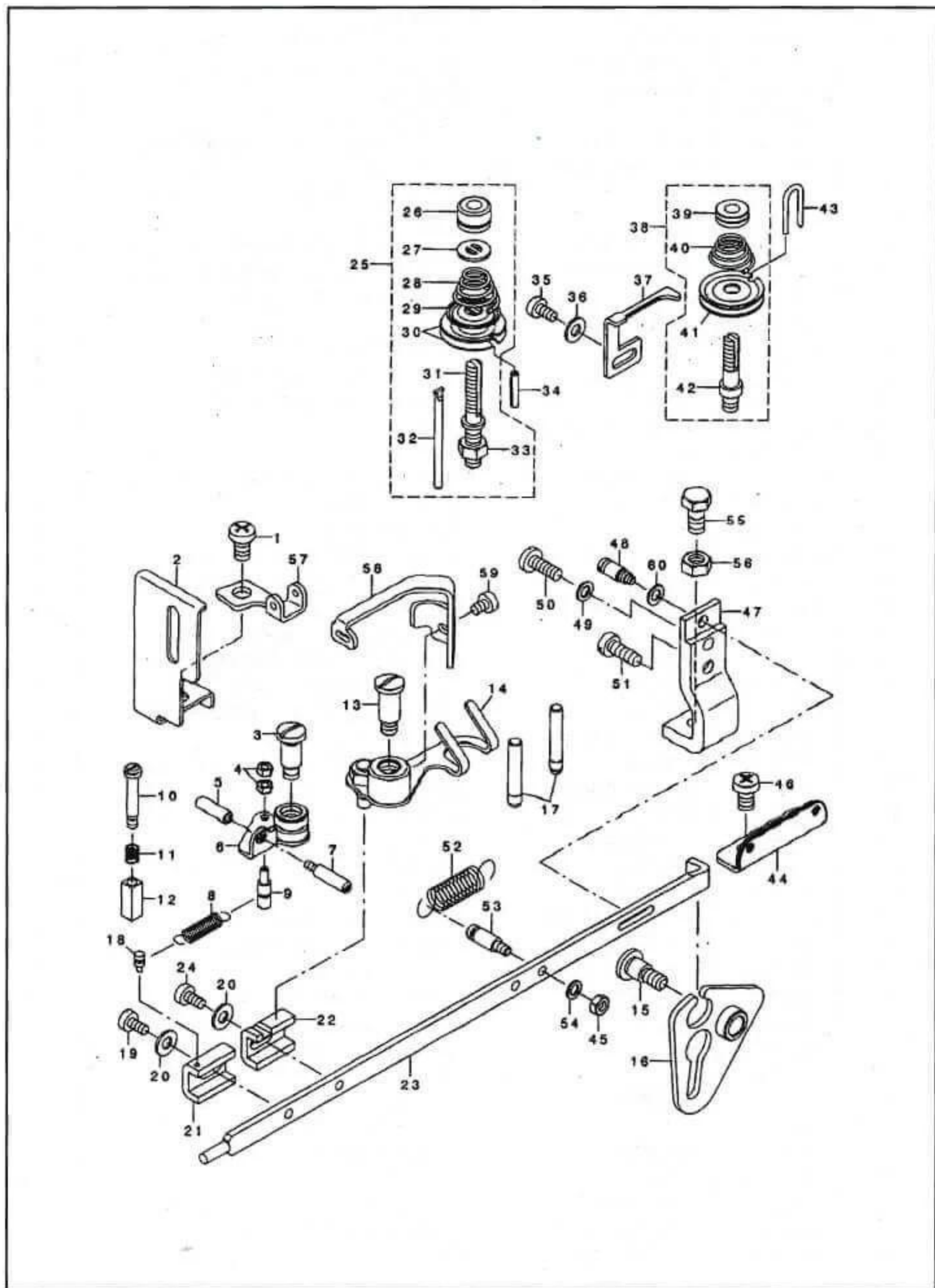

REF No 序号	PART NO 件号	DESCRIPTION 名称	Q'TY 数量	
1	85.4-1	线调整导线器安装螺钉	SCREW M6 L=12	1
2	85.14-5	针杆罩	NEEDLE BAR GUARD	1
3	85.4-3	导线装置安装段螺钉	SHOULDER SCREW	1
4	85.4-4	导线装置弹簧挂钉螺母	NUT	2
5	85.4-5	导线装置内螺纹杆	NUT	1
6	85.4-6	导线装置	NIPPER COMPL	1
7	85.4-7	导线装置外螺纹杆	LOOPER SHAFT BUSHING REAR	1
8	85.4-8	导线装置弹簧	NIPPER BAR BLOCK SPRING	1
9	85.4-9	导线装置弹簧挂钉	NIPPER BAR BAR BLOCK SPRING SCREW	1
10	85.4-10	夹线座段螺钉	HINGE SCREW D=4 H=20	1
11	85.4-11	夹线座弹簧	NIPPER SLIDE BLOCK SPRING	1
12	85.4-12	夹线座	NIPPER BLOCK	1
13	85.4-13	线调整杆组件段螺钉	SHOULDER SCREW D=7.94 H=15	1
14	85.4-14	线调整杆组件	THREAD PULL OFF LEVER ASM	1
15	85.4-15	夹线驱动杆段螺钉	SHOULDER SCREW D=7.94 H=8	1
16	85.4-16	夹线驱动杆组件	NIPPER BAR ACTUATING LEVER ASM	1
17	85.4-17	导线柱	THREAD GUIDE PIN	2
18	85.4-18	夹线杆底座弹簧销	NIPPER BAR BLOCK SPRING PIN	1
19	85.3-2	夹线杆底座安装螺钉	SCREW	1
20	90.1-26	夹线杆底座安装螺钉垫片	WASHER	2
21	85.4-19	夹线杆底座	NIPPER BAR BLOCK	1
22	85.4-20	线调整杆活动滑块	TENSION LEVER ROCKING PIECE	1
23	85.4-21	夹线杆	NIPPER BAR	1
24	85.3-2	线调整杆活动滑块安装螺钉	SCREW	1
25	85.4-22	2号夹线器组件	TENSION POST ASM NO.2	1
26	85.4-22-1	2号夹线器调节螺母	TENSION NUT	1
27	30.1-28-2	2号夹线器止动垫圈	ROTATION STOPPER	1
28	85.4-22-2	2号夹线器压力弹簧	THREAD TENSION SPRING	1
29	85.4-22-3	2号夹线器夹线压盘	THREAD TENSION DISK PRESSER	1
30	85.4-22-4	2号夹线器夹线板	THREAD TENSION DISK NO.1	2
31	85.4-22-5	2号夹线器螺杆	TENSION POST NO.2	1
32	85.4-22-6	2号夹线器挺线钉	TENSION RELEASE PIN	1
33	95.13-6	2号夹线器锁紧螺母M6	NUT M6	1
34		夹线圆盘开口销	SPRING PIN 3X16	1
35	85.4-38	释压杆安装螺钉	SCREW	1
36	90.1-46-2	释压杆安装螺钉垫片	WASHER	1
37	85.4-23	释压杆	THREAD TENSION RELEASING LEVER	1
38	85.4-24	1号夹线器组件	ASSY THREAD TENSION NO.1	1
39	85.4-24-1	1号夹线器调节螺母	THREAD TENSION NUT	1
40	85.4-24-2	1号夹线器压力弹簧	FIRST THREAD TENSION SPRING	1
41	85.4-22-4	1号夹线器夹线板	THREAD TENSION DISK NO.1	2
42	85.4-24-3	1号夹线器螺杆	THREAD TENSION POST NO.1	1
43	85.4-25	导线勾	THREAD GUIDE	1
44	85.4-26	1号导线勾	THREAD GUIDE NO.1	1
45	85.4-27	夹线杆复位弹簧挂钉螺母	NUT M4	1
46	85.4-1	1号导线勾安装螺钉	SCREW M6 L=12	1
47	85.4-28	夹线杆导向座	NIPPER BAR BEARING BLOCK	1

REF No 序号	PART NO 件号	DESCRIPTION 名称	Q'TY 数量
48	85.4-29	夹线杆导向座导向销 ADJUSTING SCREW	1
49	85.4-30	夹线杆导向座螺钉A垫圈 WASHER 5.5X10X0.8	1
50	85.4-31	夹线杆导向座螺钉A SCREW M5 L=14	1
51	85.4-32	夹线杆导向座螺钉B SCREW	1
52	85.4-33	夹线杆复位弹簧 THREAD TENSION SPRING	1
53	85.4-34	夹线杆复位弹簧挂钉 NIPPER BAR SPRING SCREW	1
54	90.3-13-11	夹线杆复位弹簧挂钉垫圈 WASHER	1
55	85.4-35	夹线杆导向座安装螺钉 SCREW M6 L=14	1
56	95.13-6	夹线杆导向座安装螺钉螺母 NUT M6	1
57	85.4-36	线调整导线器 THREAD GUIDE	1
58	85.4-37	紧线杆 LEVER	1
59	85.4-24	紧线杆安装螺钉 SCREW M4 L=6	1
60	95.10-7	夹线杆导向座导向销钉垫片 WASHER 5X10.5X1	1

## 五、送料相关部件 FEED PLATE COMPONENTS

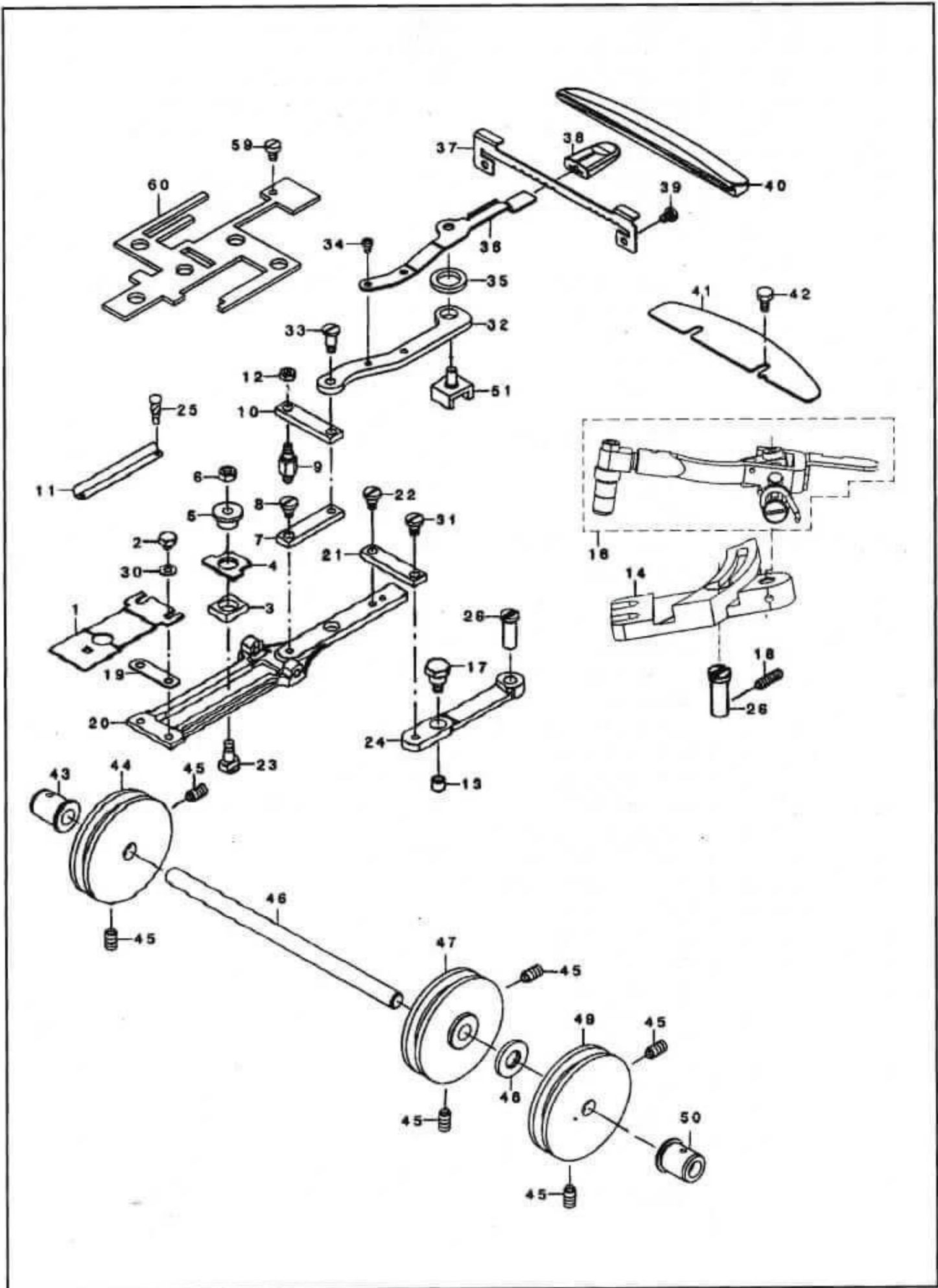

REF No 序号	PART NO 件号	DESCRIPTION 名称	Q'TY 数量	
1	85.5-1	送料板	FEED PLATE SMALL BUTTON	1
2	85.5-2	送料板安装螺钉	SCREW 3/16"X28 L=6	2
3	85.5-3	左右送料调节块	INDICATOR PIN BEARING BLOCK	1
4	85.5-4	左右送料指示器	CROSSWISE FEED INDICATION	1
5	85.5-5	左右送料指示器销	CROSSWISE FEED INDICATION PIN	1
6	95.13-6	左右送料指示器螺母	NUT M6	1
7	85.5-6	滑板连接板	SLIDE PLATE CONNECTING LINK	1
8	85.5-7	滑板连接板段螺钉	HINGE SCREW D=6.35 H=4.8	1
9	85.5-8	双头螺栓	STUD	1
10	85.5-9	中部连杆	INTERMEDI CONNETING LINK	1
11	85.5-10	左右送料刻度盘	CROSSWISE FEED GRADVATED PLATE	1
12	85.5-11	双头螺栓螺母	NUT M5	1
13	85.5-12	送料杆滚轮	CAM ROLL	1
14	85.5-58	纵向送料摆杆	FEED LEVER	1
16	85.5-60	变换杆组件		1
17	85.5-13	送料杆滚轮轴	CAM ROLL SCREW STUD	2
18	85.5-14	送料杆销轴支紧螺钉	SCREW M6X12	2
19	85.5-15	送料板垫板	SPACER PLATE	1
20	85.5-16	送料台	FEED PLATE	1
21	85.5-9	送料连杆	INTERMEDI CONNECTING LINK	1
22	85.5-7	送料连杆连接段螺钉A	HINGE SCREW D=6.35 H=4.8	1
23	85.5-18	左右送料螺钉	HINGE SCREW FOR CROSSWISE FEED	1
24	85.5-19	左右送料杆	CROSSWISE FEED LEVER	1
25		左右送料刻度盘铆钉	RIVET	1
26	85.5-20	送料杆销轴	FEED STUD	2
31	85.5-40	送料连杆连接段螺钉B	SHOULDER SCREW	3
32	85.5-58	纵向送料杆	FEED LEVER	1
33	85.5-34	纵向送料调节杆台段螺钉	SHOULDER SCREW	1
34	85.2-33-3	纵向送料调节杆螺钉	SCREW	1
35	85.5-44	纵向送料调节台油毡	OIL RETAINING FELT	1
36	85.5-30	纵向送料调节杆	HANDLE AND INDICATOR SPRING	1
37	85.5-28	纵向送料刻度盘底座	PLATE BASE	1
38	85.5-32	纵向送料调节杆手柄	KNOB	1
39	85.5-31	纵向送料刻度盘底座安装螺钉	SCREW	2
40	85.5-29	纵向送料刻度盘	GRADATE PLATE	1
41	85.5-26	纵向送料调节罩板	FEED KNOB GUIDE PLATE	1
42	85.5-27	纵向送料调节罩板螺钉	SCREW	1
43	85.5-37	送料凸轮轴套(左)	CAM SHAFT BUSHING LEFT	1
44	85.5-38	左右送料凸轮	FEED CAM ( X )	1
45	85.5-41	送料凸轮螺钉	SCREW	1
46	85.5-35	送料凸轮轴	CAM SHAFT	1
47	85.5-39	纵向送料凸轮A	FEED CAM A(Y)	1
48	85.5-42	纵向送料凸轮垫圈	WASHER	1
49	85.5-36	纵向送料凸轮	FEED CAM (Y)	1
50	85.5-43	送料凸轮轴套(右)	CAM SHAFT BUSHING RIGHT	1
51	85.5-23	纵向送料轴滑块	LENGTHWISE FEED LEVER SLIDE	1

# 六、钮夹提升相关部件 BUTTON CLAMP LIFTER COMPONENTS

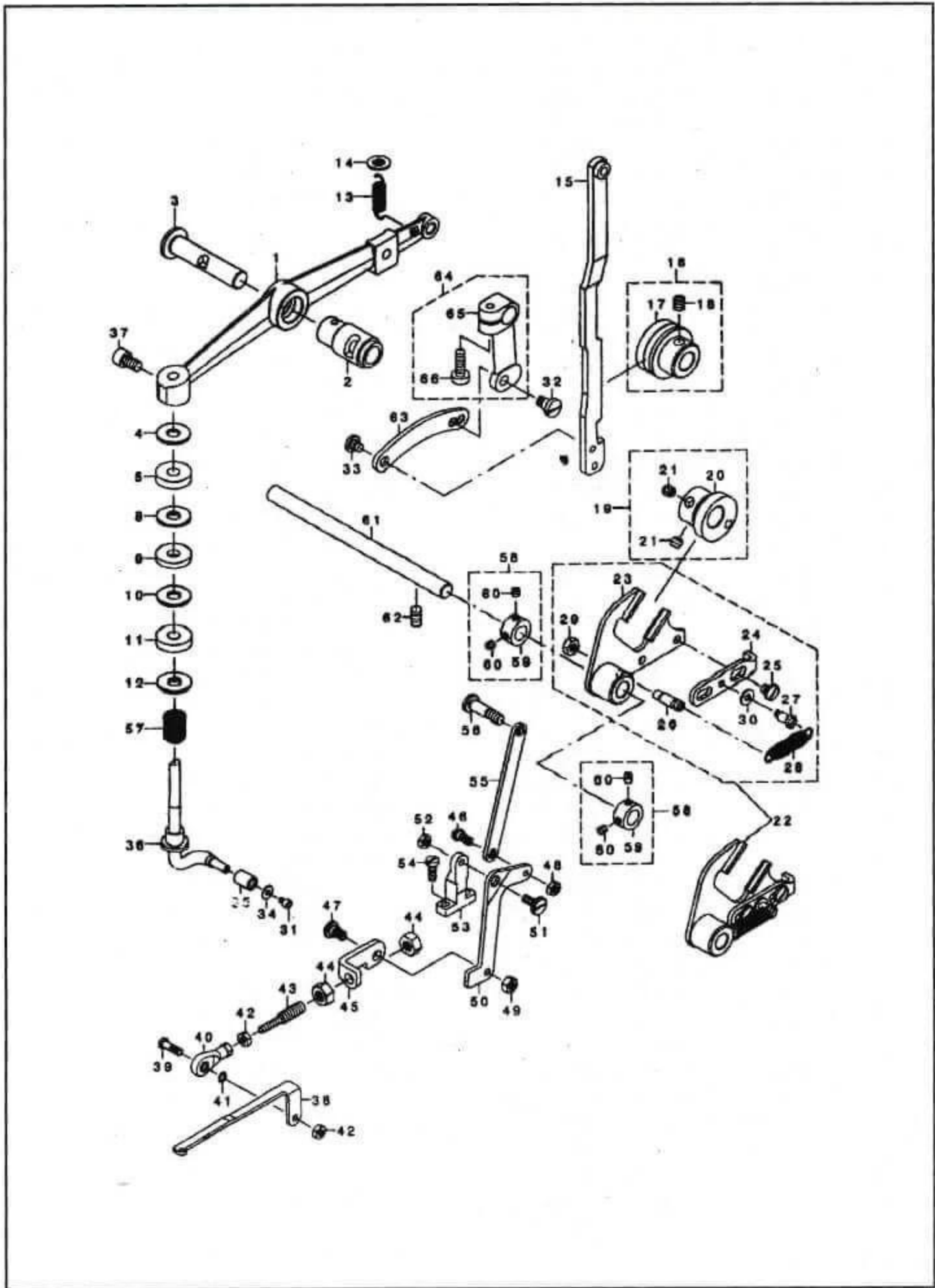

REF No 序号	PART NO 件号	DESCRIPTION 名称	Q'TY 数量	
1	85.6-1	钮夹提升杠杆	LIFTING LEVER	1
2	85.6-2	钮夹提升杠杆轴套	BUSHING	1
3	85.6-3	钮夹提升杠杆轴	NEEDLE BAR LEVER	1
4	85.6-4	钮夹提升杆垫圈A	WASHER 8.5X18X1.2	1
5	85.6-5	钮夹提升杆缓冲垫	CUSHION	1
8	85.6-4	钮夹提升杆垫圈A	WASHER	1
9	90.9-20	钮夹提升杆垫圈B	WASHER 7.5X19X1.5	1
10	90.9-20	钮夹提升杆垫圈B	WASHER 7.5X19X1.5	1
11	85.6-5	钮夹提升杆缓冲垫	CUSHION	1
12	85.6-7	钮夹提升杆垫圈C	WASHER 7X20X3.5	1
13	85.6-8	钮夹提升杠杆拉簧	SPRING	1
14	85.6-9	钮夹提升杠杆拉簧垫圈	WASHER	1
15	85.6-10	钮夹提升拉簧组件	BUTTON CLAMP LIFTING LINK	1
16	85.6-11-00	滑动滚筒组件	ASSY SLIDING ROLLER	1
17	85.6-11	滑动滚筒	SLIDING ROLLER	1
18	85.2-30	滑动滚筒螺钉	SCREW M6 L=6	1
19	85.6-12-00	提升凸轮组件	ECCENTRIC CAM	1
20	85.6-12	提升凸轮	ECCENTRIC CAM	1
21	85.6-13	提升凸轮螺钉	SCREW	2
22	85.6-14	钮夹传动叉组件	BUTTON CLAMP LIFTING LINK SET	1
23	85.6-14-1	钮夹传动叉	BUTTON CLAMP LIFTING LINK	1
24	85.6-14-2	钮夹传动叉挂钩	LIFTING HOOK	1
25	85.6-14-3	钮夹传动叉挂钩段螺钉	SHOULDER SCREW D=6.35 H=2.7	2
26	85.6-14-4	钮夹传动叉弹簧挂轴B	TENSION SPRING RACK B	1
27	85.6-14-5	钮夹传动叉弹簧挂轴段螺钉	SHOULDER SCREW D=5 H=7.2	1
28	85.6-14-6	钮夹传动叉弹簧	LIFTING HOOK SPRING	1
29	85.5-11	钮夹传动叉弹簧挂轴B螺母	NUT M5	1
30	85.6-14-7	钮夹传动叉弹簧挂轴段螺钉垫圈	WASHER	1
31	85.6-15	钮夹提升杆滚轮螺钉	SCREW M3X0.5 L=4	1
32	85.5-7	钮夹提升连接杆段螺钉A	HINGE SCREW D=6.35 H=4.8	1
33	90.4-31	钮夹提升连接杆段螺钉B	HINGE SCREW D=6.35 H=2.1	1
34	85.6-16	钮夹提升杆滚轮垫圈	WASHER M3	1
35	85.6-17	钮夹提升杆滚轮	L TYPE LIFTING BAR ROLLER	1
36	85.6-18	钮夹提升杆组件	BUTTON CLAMP LIFTING ROD A	1
37	90.8-16	钮夹提升杆组件安装螺钉	SCREW M6 L=10	1
38	85.6-19	剪线连接杆(前)	CONNECTING LINK FRONT	1
39	85.6-20	剪线连接杆(前)连接螺钉	JOINT STUD	1
40	85.6-21	剪线连接杆(前)球型连接组件	FEED ADJUSTING JOINT	1
41	85.6-22	剪线连接杆(前)连接螺钉垫圈	WASHER 5.1X7.5X0.5	1
42	85.5-11	剪线连接杆(前)连接螺钉螺母	NUT M5	1
43	85.6-23	球型连接连接螺钉	CONNECTING SCREW	2
44	85.6-24	球型连接连接螺钉螺母	NUT M8 TYPE	1
45	85.6-25	剪线连接杆(后)	CONNECTING LINK REAR	2
46	85.6-26	切线连杆段螺钉A	HINGE SCREW D=6.35 H=3.2	1
47	90.7-19-2	切线杆段螺钉A	HINGE SCREW D=7.94 H=4	1
48	40.6-32	切线杆连杆段螺钉A螺母	NUT 13/16X32	1
49	43.5-12	切线杆段螺钉A螺母	NUT 15/64*X28	1
50	85.6-27	切线杆	THREAD TRIMMING LEVER	1

REF No 序号	PART NO 件号	DESCRIPTION 名称	Q'TY 数量	
51	85.6-28	切线杆段螺钉B	SHOULDER SCREW D=6.35 H=3.1	1
52	35.5-11	切线杆段螺钉B螺母	NUT M5	1
53	85.6-29	切线杆座	THREAD TRIM LEVER BASE	1
54	85.4-31	切线杆座螺钉	SCREW M5 L=14	2
55	85.6-30	切线连杆	THREAD TRIMMING LINK	1
56	85.6-31	切线连杆段螺钉B	HINGE SCREW D=6.35 H=13.2	1
57	85.6-32	钮夹提升杆弹簧	SPRING	1
58	85.6-33-00	钮夹传动叉轴紧圈组件	THRUST COLLAR ASM D=9.5 W=8	2
59	85.6-33	钮夹传动叉轴紧圈	THRUST COLLAR D=9.5 W=8	1
60	40.3-30	钮夹传动叉轴紧圈螺钉	SCREW 11/64"X40 L=3.5	2
61	85.6-34	钮夹传动叉轴	LEVER SHAFT	1
62	85.3-11	钮夹传动叉轴支紧螺钉	SCREW	2
63	85.6-35	钮夹提升连接杆	LIFTING LINK	1
64	85.6-36-00	钮夹提升连接杆曲柄组件	LIFTING PLATE GUIDE ROD ASM	1
65	85.6-36	钮夹提升连接杆曲柄	LIFTING PLATE GUIDE ROD	1
66	85.6-37	钮夹提升杆连接杆曲柄螺钉	SCREW M5 L=16	1

## 七、驱动轴相关部件

### NEEDLE DRIVING PULLEY SHAFT COMPONENTS

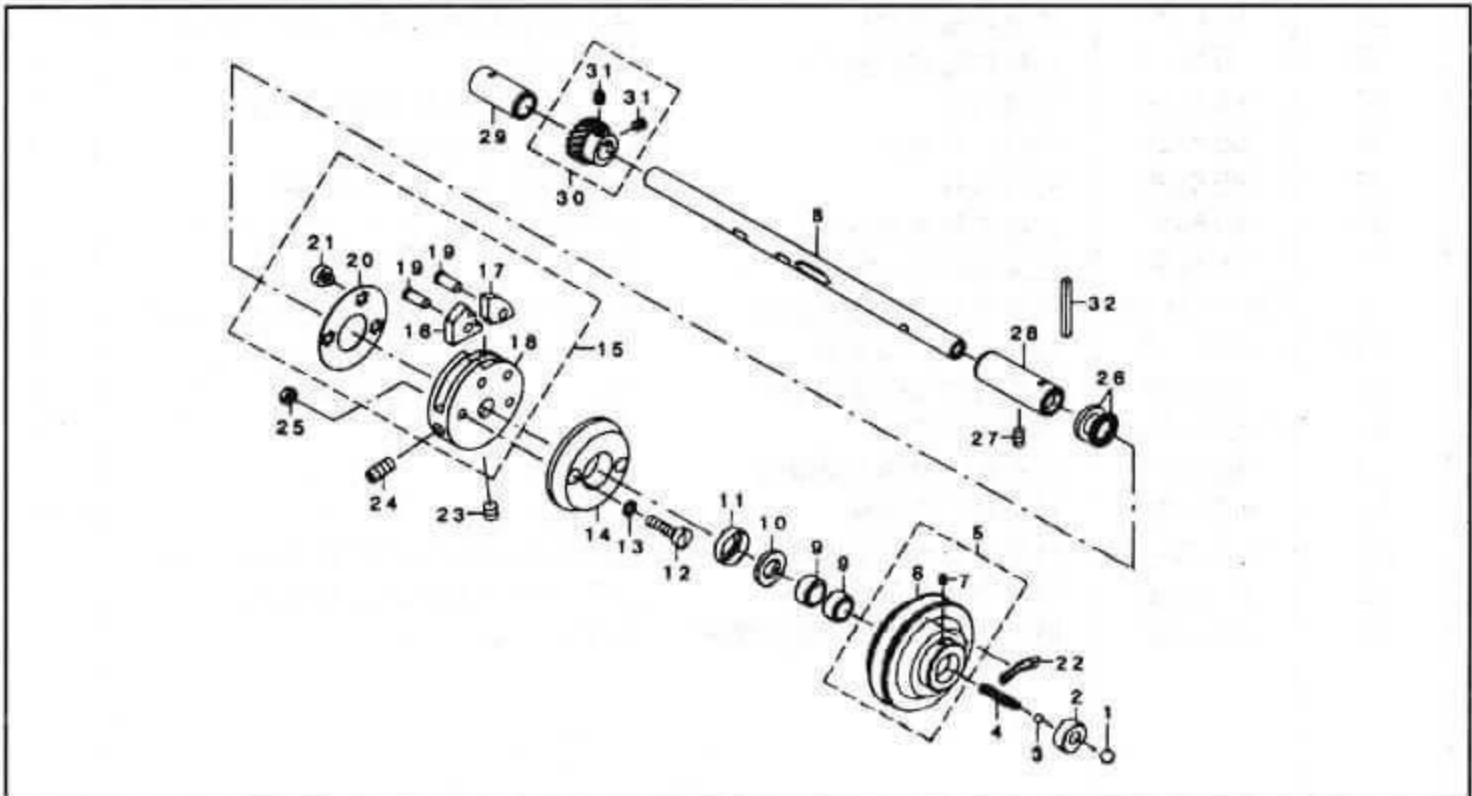

REF No 序号	PART NO 件号	DESCRIPTION 名称	Q'TY 数量
1		驱动大滚珠 BALL LARGE	1
2	85.7-1	驱动转动承座 PULLEY INSERT	1
3		小滚珠 BALL SMALL	1
4	85.7-2	驱动小滚珠弹簧 SPRING	1
5	85.7-3-00	驱动轮组件 DRIVING PULLEY ASM.	1
6	85.7-3	驱动轮 DRIVING PULLEY	1
7	85.7-4	驱动轮螺钉 SCREW M4 L=6	2
8	85.7-5	驱动轴 NEEDLE DRIVING PULLEY SHAFT	1
9		驱动轮滚针轴承 NEEDLE BEARING	2
10	85.7-6	驱动轮油毡 GREASE RTETAINING WICK	1
11	85.7-7	驱动轮油封 RETAINING WASHER	1
12	85.7-8	离合从动轮螺钉 SCREW M6 L=23.5	2
13	85.7-9	离合从动轮螺钉垫圈 WASHER 6.2X9.5X1	2
14	85.7-10	离合从动轮 NEEDLE DRIVING PULLEY CLUTCH D	1
15	85.7-13-00	停车凸轮组件 STOP MOTION DISC ASM	1
16	85.7-11	停车爪A STOP MOTION DISC LATCH A	1
17	85.7-12	停车爪B STOP MOTION DISC LATCH B	1
18	85.7-13	停车凸轮 STOP MOTION DISC	1
19	85.7-14	停车爪销 STOP MOTION PAWL SHAFT	2
20	85.7-15	停车凸轮垫片 STOP MOTION DISC WASHER	1
21	85.7-16	停车凸轮垫片螺钉 SCREW M6 L=4.5	1
22	85.7-17	驱动轮转动方向标志 DIRECTION LABEL	1
23	85.7-18	停车凸轮螺钉A SCREW M8X8	1
24	85.7-19	停车凸轮螺钉B SCREW M8 L=17	1
25	85.7-20	离合器从动轮螺钉螺母 NUT M6	2
26	85.7-21	驱动轴套(右)端面轴承 THRUST BALL BEARING	1
27	85.3-11	驱动轴套(右)支紧螺钉 SCREW	1
28	85.7-22	驱动轴套(右) PULLEY SHAFT BUSHING RIGHT	1
29	85.7-23	驱动轴套(左) PULLEY SHAFT BUSHING LEFT	1
30	85.7-24	驱动齿轮 DRIVING GEAR	1
31	85.7-25	驱动齿轮螺钉 SCREW 1/4 "X40 L=6	1

## 八、针杆驱动机构部件

### NEEDLE BAR DRIVING MECHANISM COMPONENTS

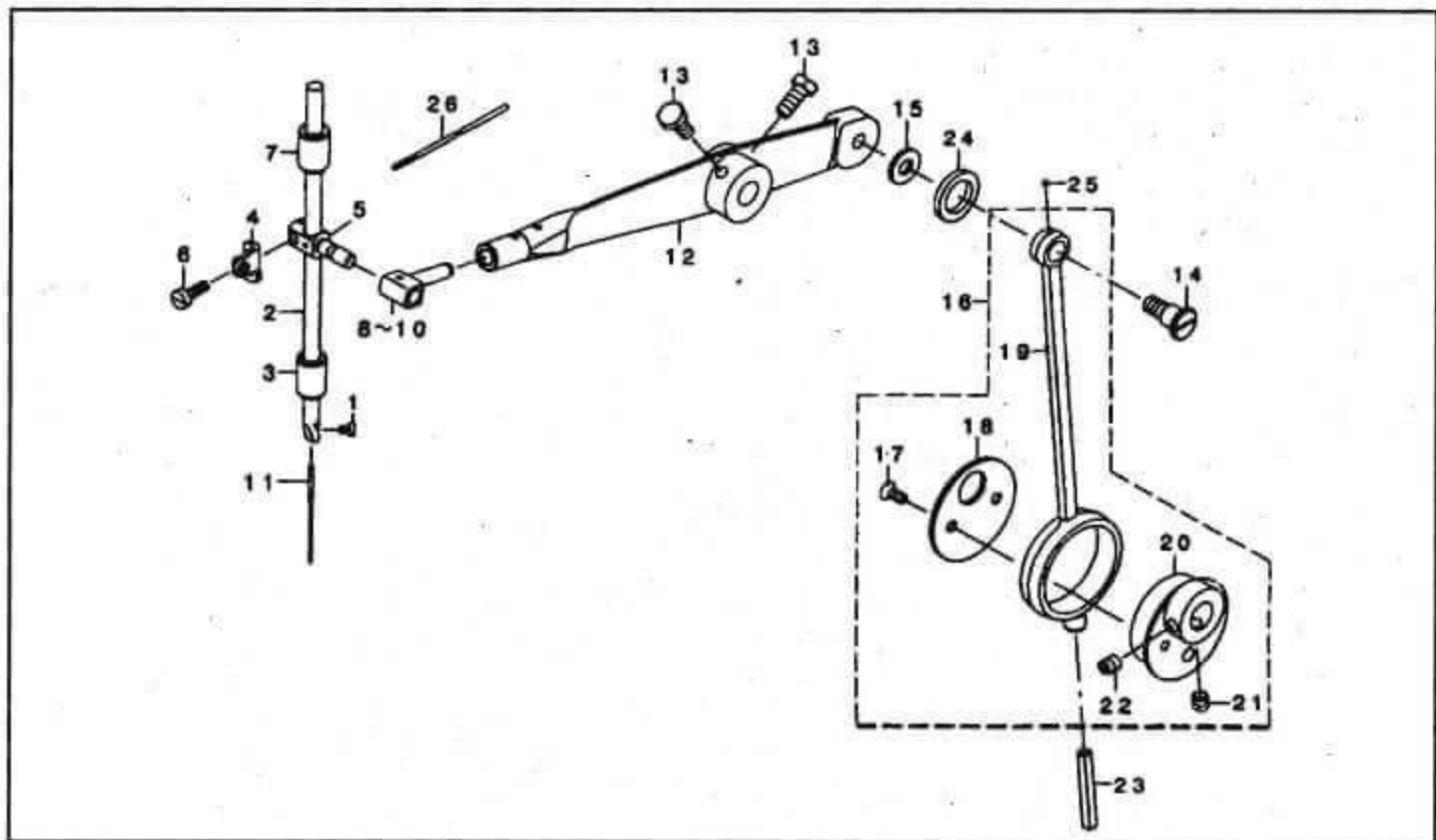

REF No 序号	RART NO 件号	DESCRIPTION 名称	Q'TY 数量	
1	10.2-44	夹针螺钉	SCREW 1/8" X44 L=4.5	1
2	85.8-1	针杆	NEEDLE ROD	1
3	85.8-2	针杆下套	NEEDLE BAR BUSHING LOWER	1
4	85.8-3	导线勾	NEEDLE BAR BALANCE	1
5	85.8-4	针杆接头	NEEDLE BAR CLAMP	1
6	85.8-5	针杆接头螺钉	SCREW M4 L=12	1
7	85.8-6	针杆上套	NEEDLE BAR BUSHING UPPER	1
10	85.8-7	针杆接头连接块	NEEDLE BAR SLIDE BLOCK	1
11		机针	NEEDLE TQX1 16#	1
12	85.8-8	针杆驱动杠杆	NEEDLE BAR DRIVING LEVER	1
13	85.4-35	针杆驱动杠杆螺钉	SCREW M6 L=14	2
14	85.8-9	针杆驱动连杆段螺钉	SHOULDER SCREW D=9.53 H=8	1
15	85.8-10	针杆驱动连杆段螺钉垫圈	WASHER	1
16	85.8-13-00	针杆驱动凸轮组件	CRANK ROD ASM	1
17	30.1-32	针杆驱动凸轮压板螺钉	SCREW 11/64 "X40 L=8.5	2
18	85.8-11	针杆驱动凸轮压板	THRUST HOLDER	1
19	85.8-12	针杆驱动 连杆	CRANK ROD	1
20	85.8-13	针杆驱动凸轮	ECCENTRIC CAM	1
21	90.2-36	针杆驱动凸轮螺钉A	SCREW 1/4" X40 L=6	1
22	85.8-14	针杆驱动凸轮螺钉B	SCREW 1/4 "X40 L=8.5	1
23	85.8-15	针杆驱动连杆下油毡	OIL WICK	1
24	85.5-44	针杆驱动 连杆段螺钉油毡	OIL RETAINING FELT	1
25	85.8-17	针杆驱动连杆上油线	OIL WICK	1
26	85.8-18	油线	OIL WICK	1

## 九、止动机构部件

### STOP MOTION MECAHNISM COMPONENTS

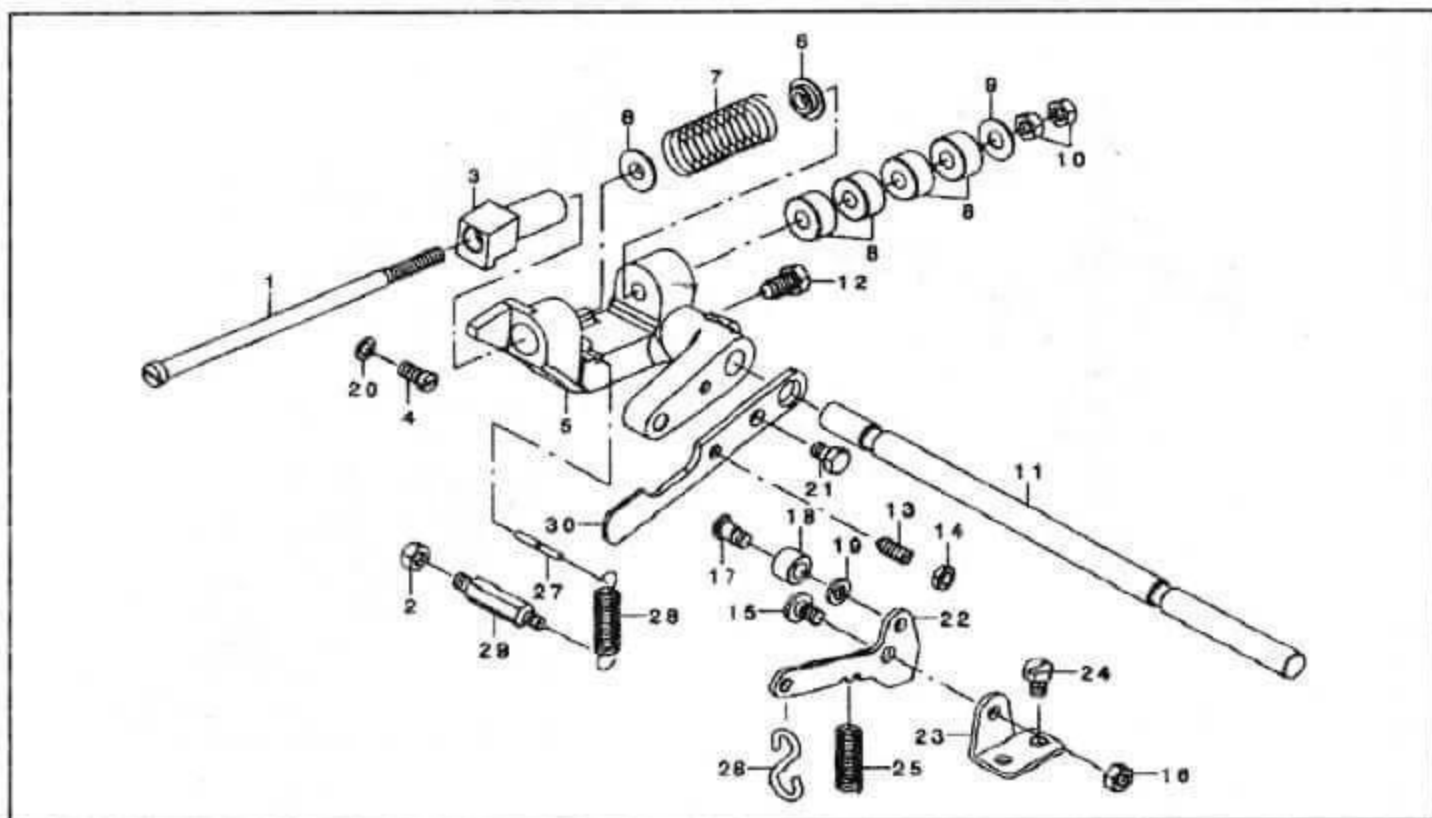

REF No 序号	PART NO 件号	DESCRIPTION 名称	Q'TY 数量
1	90.9-15	止动柱塞杆	1
2	85.7-20	挂弹簧销钉锁紧螺母	1
3	85.9-1	止动块	1
4	85.9-2	止动架本体限位螺钉	1
5	85.9-3	止动架本体	1
6	90.9-19	止动块垫圈(前)	2
7	85.9-4	止动块弹簧	1
8	90.9-17	止动块橡胶垫圈	4
9	85.9-5	止动块垫圈后	1
10	40.3-14	止动柱塞杆螺母	2
11	85.9-6	止动杆轴	1
12	85.9-7	止动轴螺钉	1
13	85.9-8	钢球压板调节螺钉	1
14	43.5-12	钢球压板调节螺钉螺母	1
15	85.9-9	止动杠杆段螺钉	1
16	95.13-6	止动杠杆段螺钉螺母	1
17	85.9-10	止动杠杆滚轮段螺钉	1
18	85.9-11	止动杠杆滚轮	1
19	85.9-12	止动杠杆滚轮垫圈	1
20	85.9-13	止动架本体限位螺钉垫圈	1
21	85.9-14	钢球压板安装螺钉	1
22	85.9-15	止动杠杆	1
23	85.9-16	止动杠杆架	1
24	85.9-17	止动杠杆架螺钉	2
25	85.9-18	止动杠杆弹簧	1
26	43.8-10	S型挂钩	1
27	85.9-20	止动架本体弹簧挂销	1
28	85.9-21	止动架本体弹簧	1
29	85.9-22	止动架本体弹簧销钉	1
30	85.9-23	钢球压板	1

# 十、针数调节相关部件

## STITCH SELECTING PARTS COMPONENTS

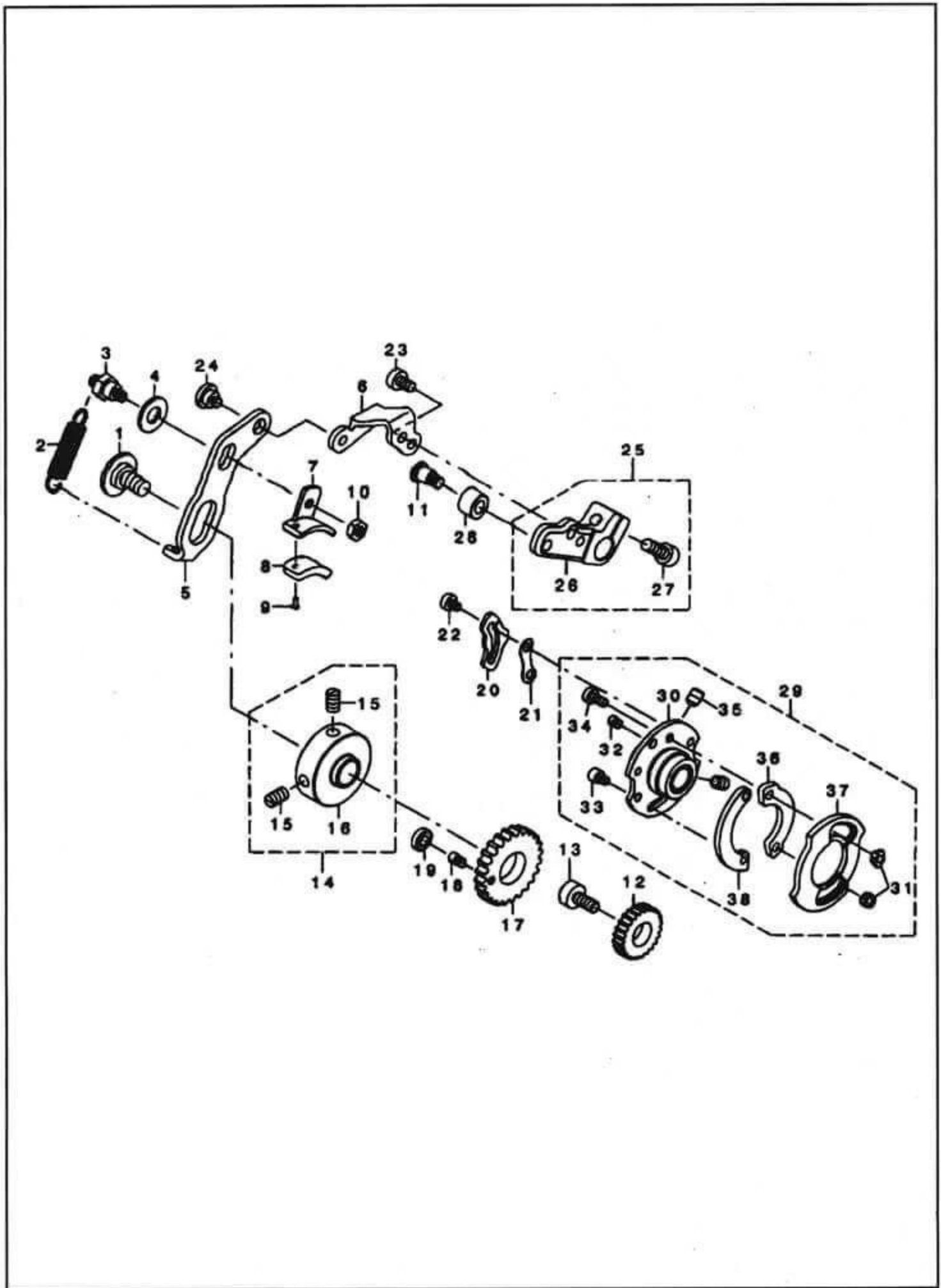

REF No 序号	PART NO 件号	DESCRIPTION 名称	Q'TY 数量	
1	85.10-1	减速杆段螺钉(大)	SHOULDER SCREW D=12.7 H=3.4	1
2	85.10-2	摩擦片弹簧	SPRING FOR FRICTION PLATE	1
3	85.10-3	摩擦片转动轴	FRICTION PLATE ROTATING SHAFT	1
4	85.10-4	减速摩擦片转动轴垫圈	WASHER 8.5X18X1.6	1
5	85.10-5	减速杆	SPEED SLOWER LEVER	1
6	85.10-6	调节板	FITING PLATE	1
7	85.10-7	减速摩擦片座	FRICTION PLATE HOLDER	1
8	85.10-8	减速摩擦片	SPEER SLOWER FRICTION PLATE	1
9		减速摩擦片销钉	POSITIONING PIN	2
10	40.7-7	减速摩擦片转动轴螺母	NUT 11/64"X40	1
11	85.9-10	针数调节臂滚轮段螺钉	SHOULDER SCREW D=7.14 H=7	1
12	85.10-9	针数齿轮(中)	STITCH SELECTING SPUR GEAR	1
13	85.10-10	齿轮轴	INTERMEDIATE GEAR SHAFT	1
14	85.10-11-00	减速摩擦轮组件	ASSY SPEED SLOWER FRICTION	1
15	85.3-11	减速摩擦轮螺钉	SCREW	2
16	85.10-11	减速摩擦轮	SPEED SLOWER FRICTION WHEEL	1
17	85.10-12	针数齿轮(大)	GEAR LAGER	1
18	85.10-13	针数齿轮(大)滚轮螺钉	SCREW	1
19	85.10-14	针数齿轮(大)滚轮	ROLLER	1
20	85.10-15	线约束槽	THREAD BIND NOTCH	1
21	85.10-16	线约束垫片	SPACER	1
22	85.10-17	线约束槽螺钉	SCREW M4X0.5 L=4.5	2
23	85.2-15	调节板螺钉	SCREW M5 L=8	2
24	90.1-29-5	减速杆段螺钉(小)	HINGE SCREW D=8 H=3.4	1
25	85.10-18-00	针数调节臂组件	STITCH ADJUSTING ARM ASM	1
26	85.10-18	针数调节臂	STITCH ADJUSTING ARM	1
27	85.10-19	针数调节臂螺钉	SCREW M6 L=16	1
28	85.9-11	针数调节臂滚轮	STITCH ADJUST ROLLER	1
29	85.10-20-00	针数调节凸轮组件	STITCH ADJUST CAM ASSY	1
30	85.10-20	针数调节凸轮	STITCH ADJUST CAM	1
31	85.10-21	针数调节凸轮螺母	NUT	2
32	85.10-22	针数调节凸轮螺钉A	SCREW	1
33	85.10-23	针数调节凸轮螺钉B	SCREW M4X0.7 L=5	1
34	40.4-30	针数调节凸轮螺钉C	SCREW	2
35	85.10-24	针数调节凸轮支紧螺钉	SCREW	1
36	85.10-25	针数调节凸轮垫片	SOACER	1
37	85.10-26	针数凸轮A	STITCH CAM	1
38	85.10-27	针数凸轮片	STOP MOTION CAM SHOE	1

# 十一、打结相关部件

## THREAD BIND NOTCH COMPONENTS

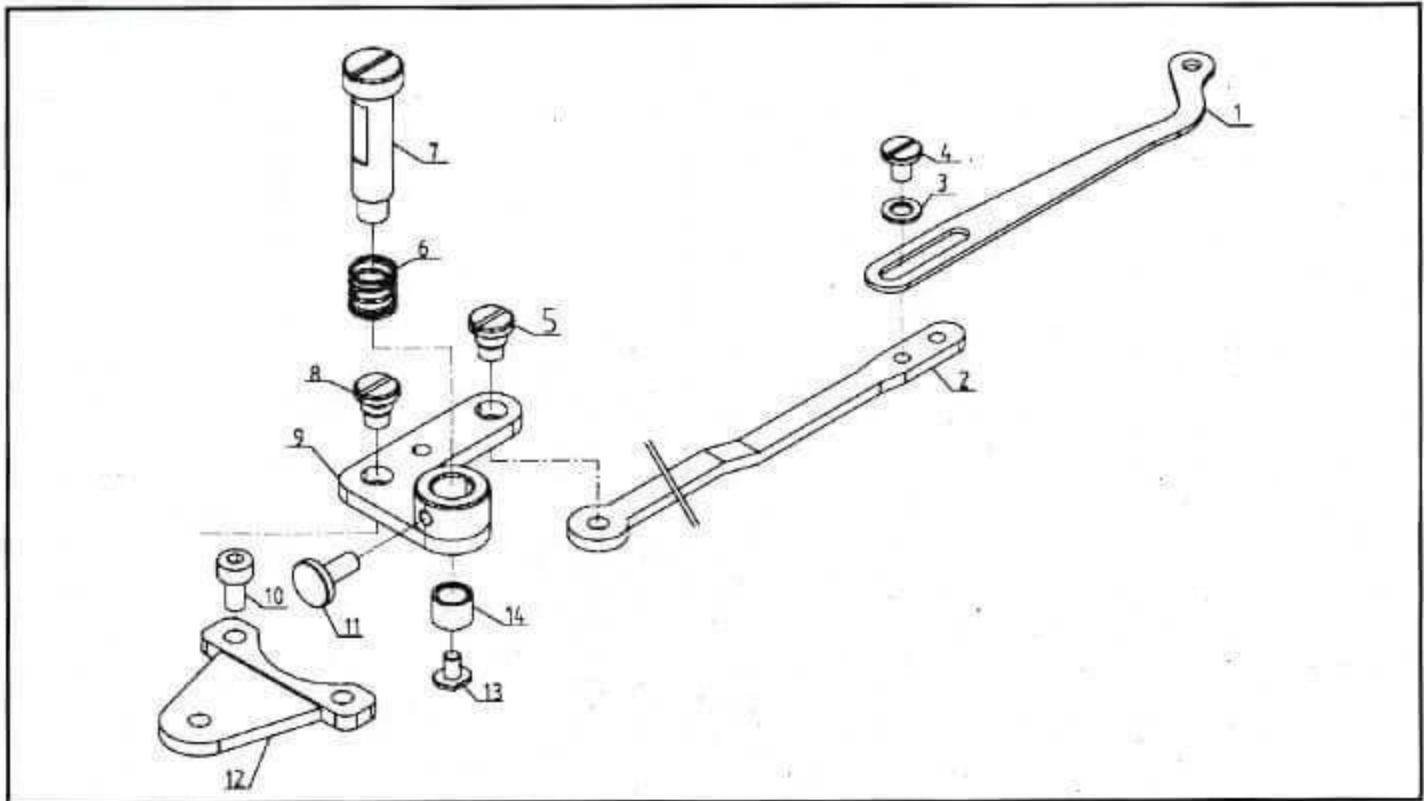

REF No 序号	PART NO 件号	DESCRIPTION 名称	Q'TY 数量
1	85.11-1	打结短连杆 THREAD BIND LEVER	1
2	85.11-2	连接长连杆 CONNECTING PLATE LARGE	1
3	85.2-33-3	连接短连杆垫圈 WASHER	2
4	85.2-7	连接短连杆螺钉 SCREW	2
5	85.11-10	打结曲柄螺钉 SCREW	2
6	85.1-9	打结曲柄销弹簧 SPRING	2
7	85.11-4	打结曲柄控制销 PIN	1
8	85.11-10	打结曲柄固定螺钉 SCREW	1
9	85.11-3	打结曲柄组件 THREAD BIND ARM	1
10	85.4-38	打结曲支撑板安装螺钉 SCREW	2
11	85.11-5	打结控制螺钉 SCREW	1
12	85.11-6	打结曲柄支撑板 THREAD BIND SUPPORT PLATE	1
13	85.11-8	滚轮安装螺钉 SCREW	1
14	85.11-7	打结曲柄滚轮 ROLLER	1

## 十二、线架部件 THREAD STAND COMPONENTS

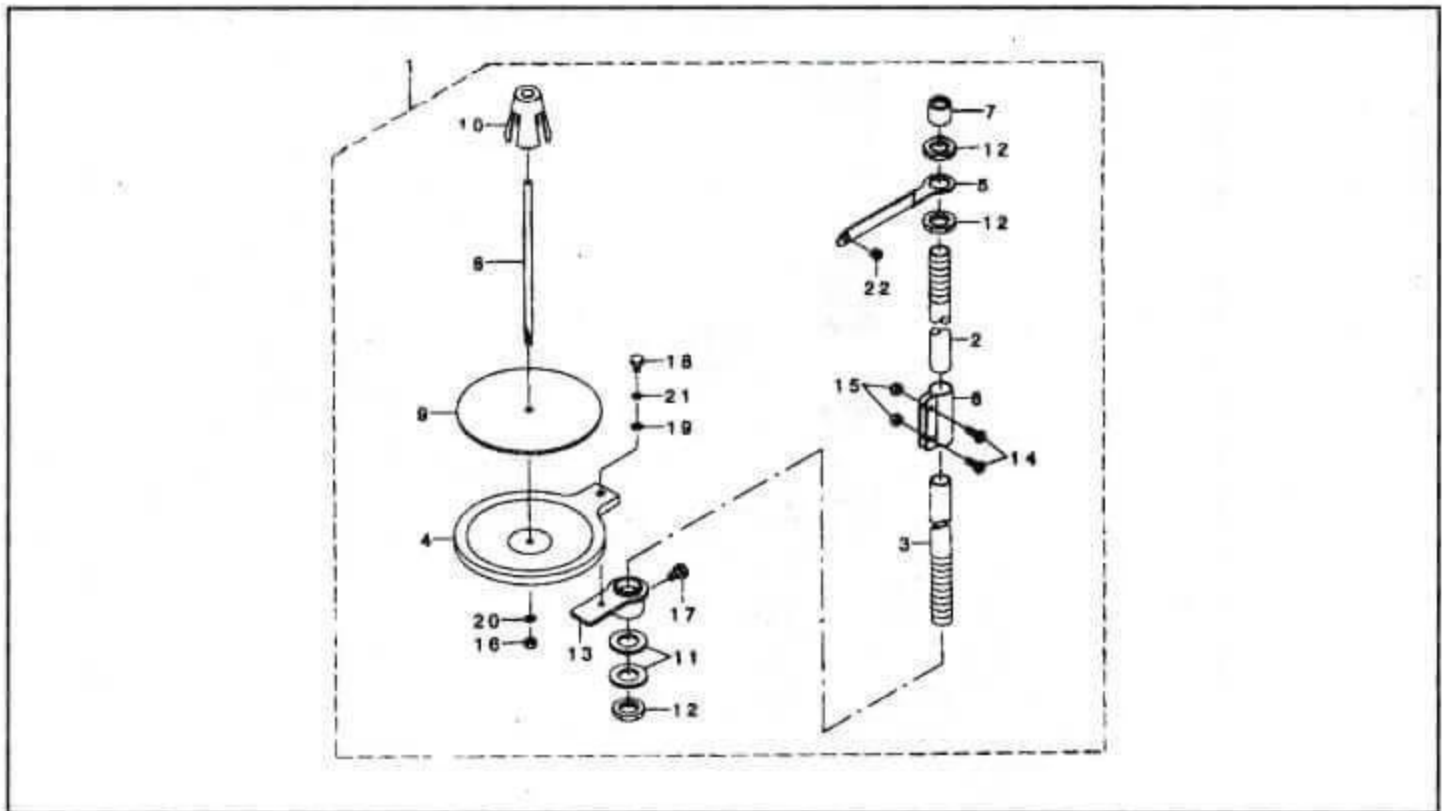

REF No 序号	PART NO 件号	DESCRIPTION 名称	Q'TY 数量
1	85.12-1	线架 THREAD STAND ASM	1
2	85.12-1-2	线架杆上节 SPOOL REST ROD,UPPER	1
3	20.8-6-1	线架杆下节 SPOOL REST ROD,LOWER	1
4	85.12-1-4	线盘 THREAD STAND HOLDER PLATE	1
5	85.12-1-3	线架过线柱 THREAD RAISING THREAD GUIDE A	2
6	20.8-6-5	支撑柱连接套 SPOOL REST ROD JOINT	2
7	20.8-6-4	线架杆顶防护皮套 SPOOL REST ROD RUBBER CAP	1
8	20.8-6-6	插线钉 SPOOL PIN	1
9	20.8-6-9	线盘轮垫 SPOOL REST CUSHION	2
10	20.8-6-7	线盘防松垫 SPOOL RETAINER	2
11	20.8-6-2	线架杆垫片 WASHER 16X30X2.6	2
12		线架过线柱螺母 NUT M16X1.5	3
13	85.12-1-1	托架 SPOOL REST BRACKET ASM	1
14		支撑柱连接螺钉 SCREW M5 L=14	2
15		支撑柱连接螺母 NUT M5	2
16		线架支撑螺母 NUT M5	1
17		托架安装螺钉 SCREW M6 L=10	1
18		线盘安装螺钉 SCREW M5X0.8 L=8	1
19		线盘安装螺钉平垫片 WASHER 5.2X9.5X0.6	1
20		线架杆垫片 SPRING WASHER	1
21		线盘安装螺钉弹簧垫圈 SPRING WASHER 5.2X8.2X1	1
22	20.8-6-11	过线环护套 THREAD GUIDE	1
			1
			1